



MPG Series

Power Supply Unit

MPG A1000G PCIE5

MPG A850G PCIE5

MPG A750G PCIE5

User Guide

English

Italiano

Deutsch

Język polski

Français

Português

Русский

Español

日本語

Türkçe

한국어

Čeština

繁體中文

Slovenčina

简体中文

Contents

Specifications	2
Dimensions	3
Number of Power Connectors	4
Detachable Connectors	5
Connectivity and Cable Lengths	6
PCIe 16 Pin Cable Installation	8
Zero Fan Button.....	9

Specifications

1000W					
Voltage	+5V	+3.3V	+12V	-12V	+5Vsb
Max load	22.0A	22.0A	83.5A	0.3A	3.0A
Min load	0.0A	0.0A	0.0A	0.0A	0.0A
Combined power (+5V&+3.3V)	120W		1000W	3.6W	15.0W
Total Power	1000W				
Regulation	± 5%	± 5%	± 5%	± 5%	± 5%
Ripple & Noise	30mVp-p	30mVp-p	50mVp-p	40mVp-p	40mVp-p

850W					
Voltage	+5V	+3.3V	+12V	-12V	+5Vsb
Max load	22.0A	22.0A	70.8A	0.3A	3.0A
Min load	0.0A	0.0A	0.0A	0.0A	0.0A
Combined power (+5V&+3.3V)	120W		850W	3.6W	15.0W
Total Power	850W				
Regulation	± 5%	± 5%	± 5%	± 5%	± 5%
Ripple & Noise	30mVp-p	30mVp-p	50mVp-p	40mVp-p	40mVp-p

750W					
Voltage	+5V	+3.3V	+12V	-12V	+5Vsb
Max load	22.0A	22.0A	62.5A	0.3A	3.0A
Min load	0.0A	0.0A	0.0A	0.0A	0.0A
Combined power (+5V&+3.3V)	120W		750W	3.6W	15.0W
Total Power	750W				
Regulation	± 5%	± 5%	± 5%	± 5%	± 5%
Ripple & Noise	30mVp-p	30mVp-p	50mVp-p	40mVp-p	40mVp-p

Dimensions

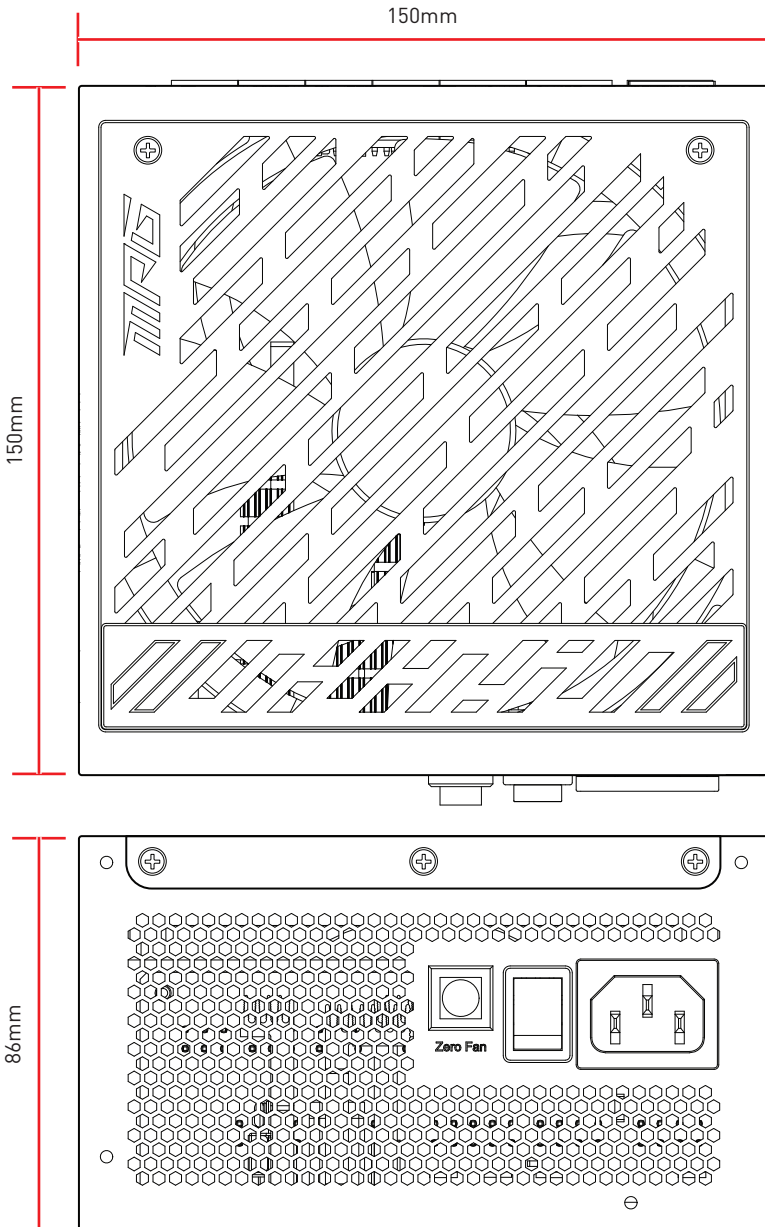

Number of Power Connectors

Power Connectors	A1000G PCIE5	A850G PCIE5	A750G PCIE5
ATX12V (Motherboard) 20+4 pin	1	1	1
PCIe 16 pin	1	1	1
EPS12V (CPU) 4+4 pin	2	2	2
PCIe (VGA) 6+2 pin	6	6	6
SATA 15 pin	12	8	8
Peripheral (PATA) 4 pin	4	4	4
FDD 4 pin	1	1	1

Detachable Connectors

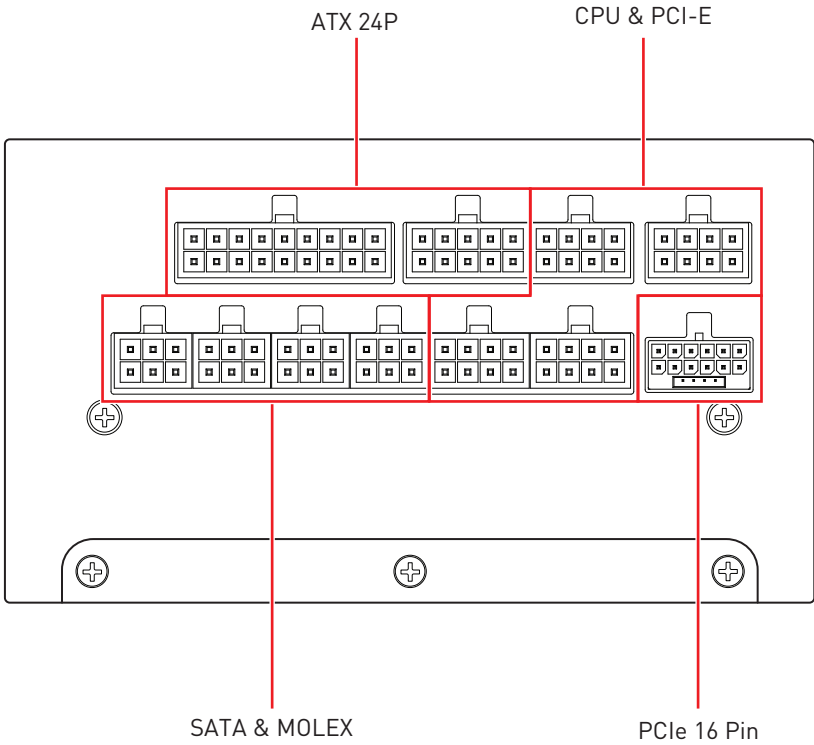

Connectivity and Cable Lengths

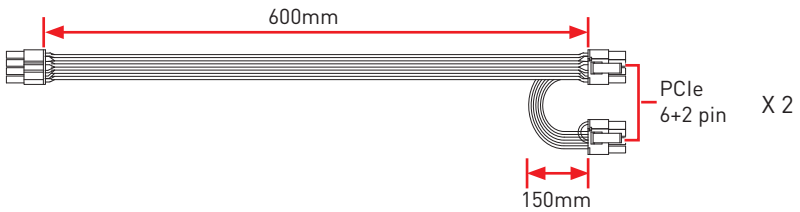
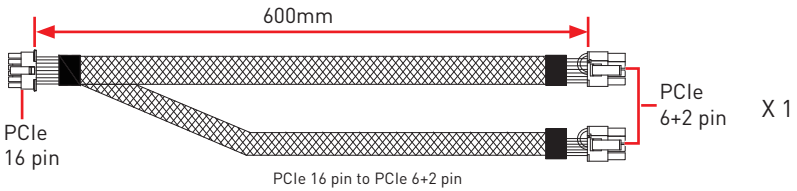
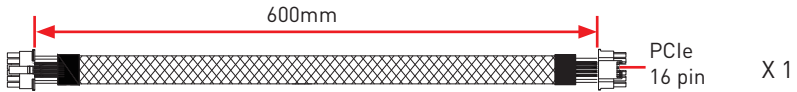
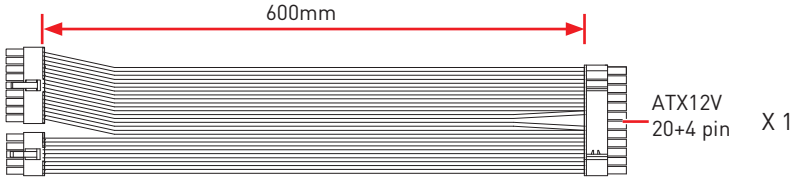

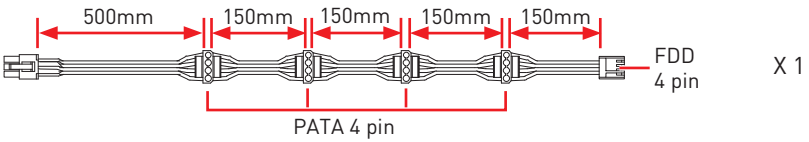
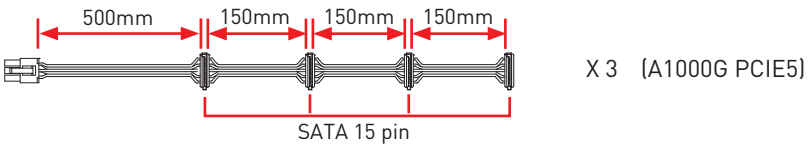
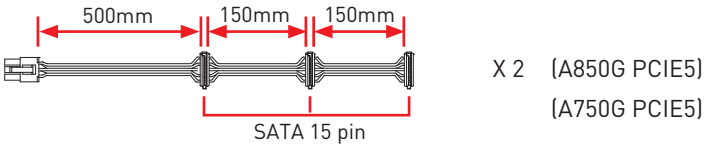
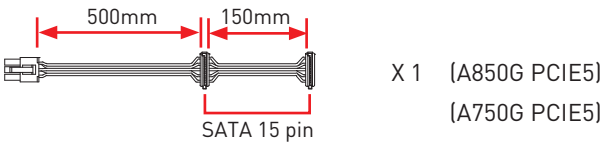
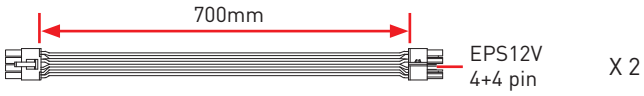

PCIe 16 Pin Cable Installation

 **CAUTION**

Please fully insert the cable before use.

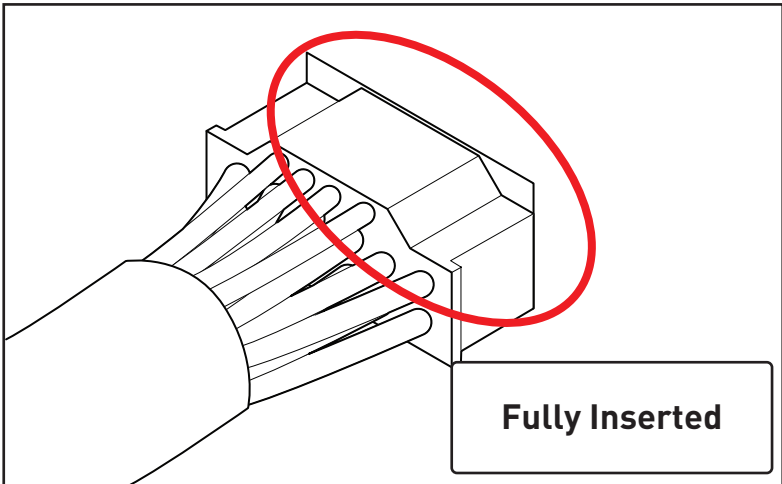
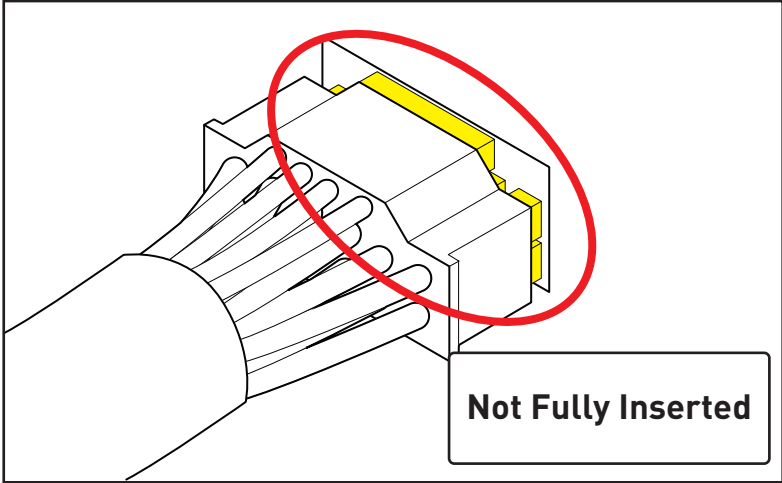

Zero Fan Button

Press the Zero Fan button to turn **Zero RPM Fan Mode** ON or OFF.

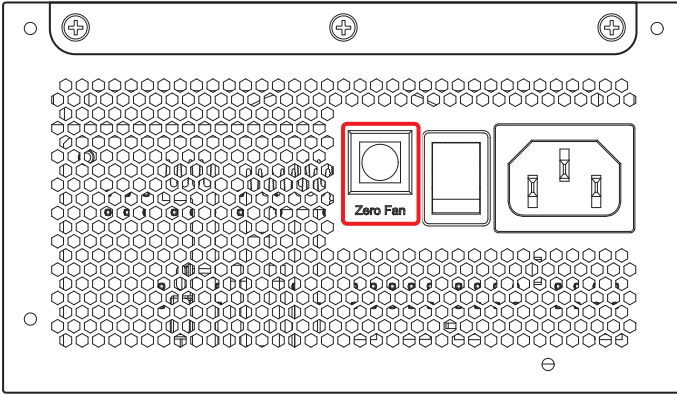

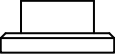
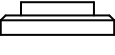
Zero Fan Button	Zero RPM Fan Mode	Description
 Unpressed	ON (Default)	The PSU fan stops when the system load falls below the designated level.
 Pressed	OFF	The PSU fan runs constantly.

Important

Zero RPM Fan Mode is active by default; press the button to deactivate it.

Inhalt

Spezifikationen	2
Abmessungen	3
Zahl der Stromanschlüsse	4
Lösbare Steckverbinder	5
Konnektivität und Kabellängen	6
PCIe 16 Pin Kabelinstallation	8
Zero Fan Taste (Lüfter-Taste)	9

Spezifikationen

1000W					
Spannung	+5V	+3,3V	+12V	-12V	+5Vsb
Max. Belastung	22,0A	22,0A	83,5A	0,3A	3,0A
Min. Belastung	0,0A	0,0A	0,0A	0,0A	0,0A
Kombinierte Stromversorgung (+5V&+3,3V)	120W		1000W	3,6W	15,0W
Gesamtleistung	1000W				
Lastregelung	± 5%	± 5%	± 5%	± 5%	± 5%
Restwelligkeit	30mVp-p	30mVp-p	50mVp-p	40mVp-p	40mVp-p

850W					
Spannung	+5V	+3,3V	+12V	-12V	+5Vsb
Max. Belastung	22,0A	22,0A	70,8A	0,3A	3,0A
Min. Belastung	0,0A	0,0A	0,0A	0,0A	0,0A
Kombinierte Stromversorgung (+5V&+3,3V)	120W		850W	3,6W	15,0W
Gesamtleistung	850W				
Lastregelung	± 5%	± 5%	± 5%	± 5%	± 5%
Restwelligkeit	30mVp-p	30mVp-p	50mVp-p	40mVp-p	40mVp-p

750W					
Spannung	+5V	+3,3V	+12V	-12V	+5Vsb
Max. Belastung	22,0A	22,0A	62,5A	0,3A	3,0A
Min. Belastung	0,0A	0,0A	0,0A	0,0A	0,0A
Kombinierte Stromversorgung (+5V&+3,3V)	120W		750W	3,6W	15,0W
Gesamtleistung	750W				
Lastregelung	± 5%	± 5%	± 5%	± 5%	± 5%
Restwelligkeit	30mVp-p	30mVp-p	50mVp-p	40mVp-p	40mVp-p

Abmessungen

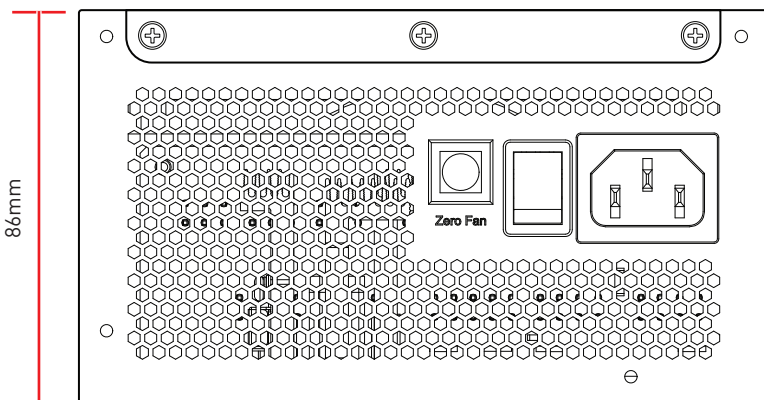
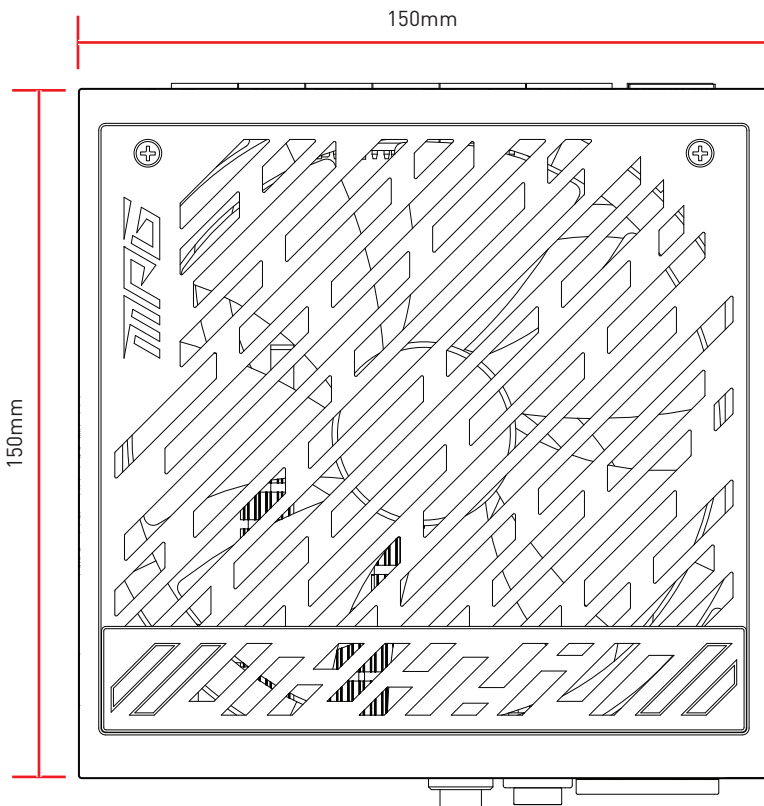

Zahl der Stromanschlüsse

Stromanschlüsse	A1000G PCIE5	A850G PCIE5	A750G PCIE5
ATX12V (Motherboard) 20+4 Pin	1	1	1
PCIe 16 Pin	1	1	1
EPS12V (CPU) 4+4 Pin	2	2	2
PCIe (VGA) 6+2 Pin	6	6	6
SATA 15 Pin	12	8	8
Peripheriegerät (PATA) 4 Pin	4	4	4
FDD 4 Pin	1	1	1

Lösbare Steckverbinder

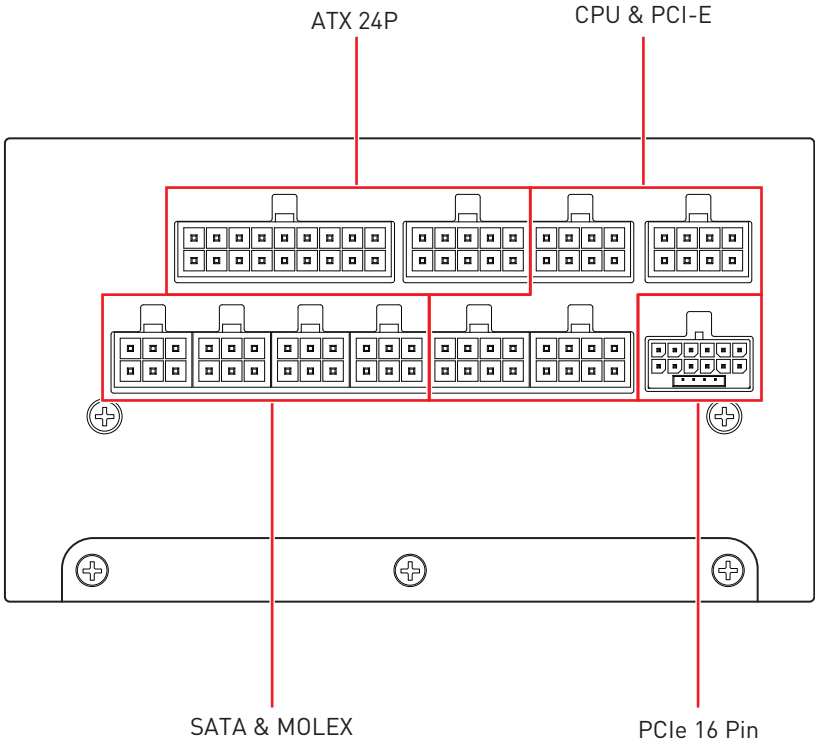

Konnektivität und Kabellängen

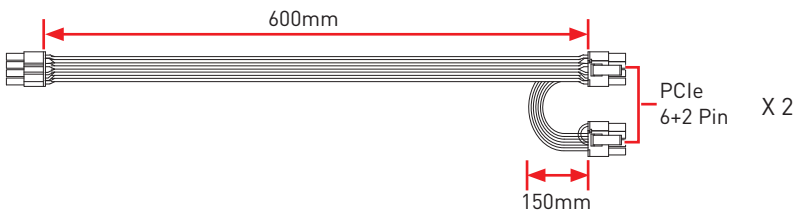
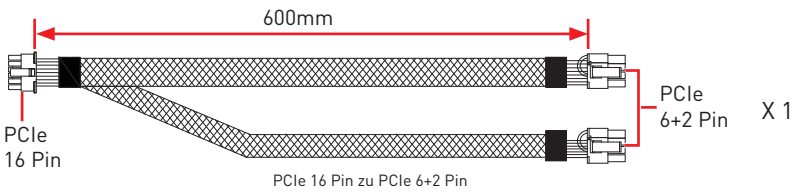
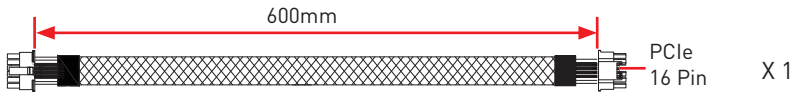
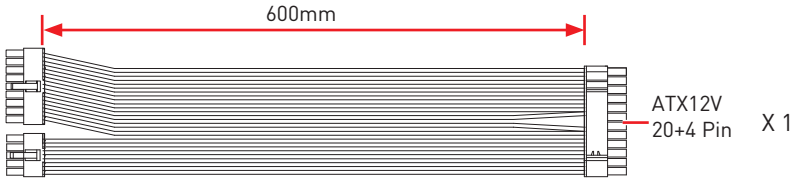

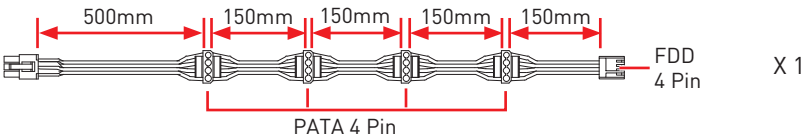
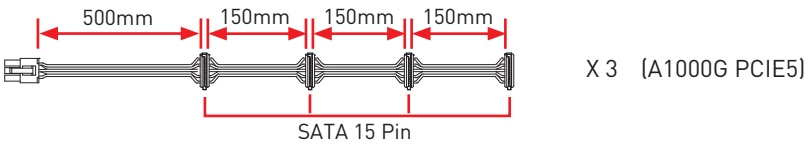
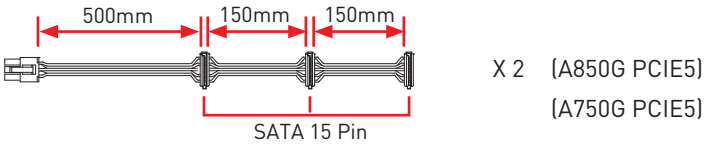
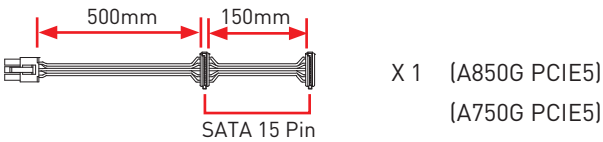

PCIe 16 Pin Kabelinstallation

 **ACHTUNG**

Vor der ersten Verwendung führen Sie bitte das Kabel vollständig in eine der Buchsen ein.

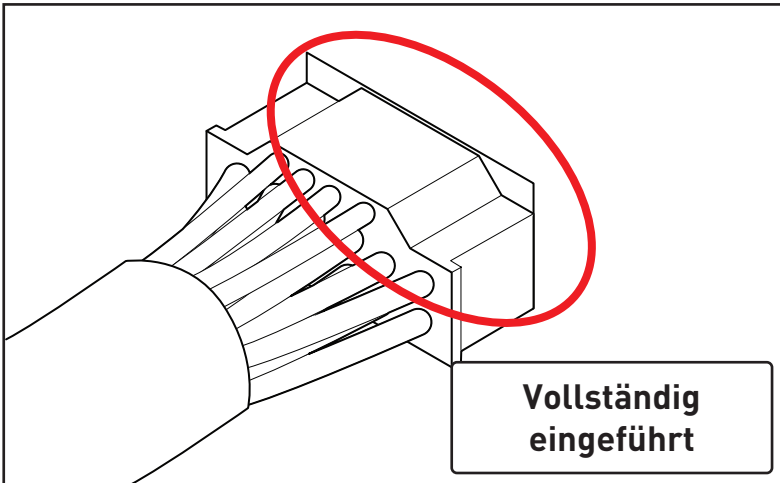
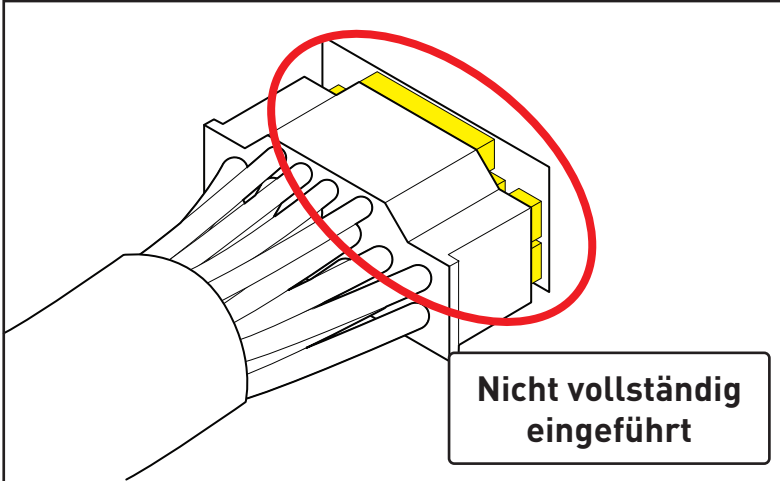

Zero Fan Taste (Lüfter-Taste)

Drücken Sie die Lüfter-Taste, um den **Zero RPM Fan Modus** ein- oder auszuschalten.

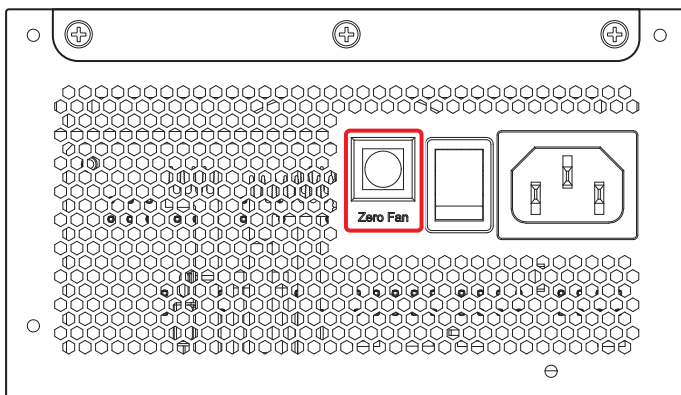

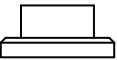
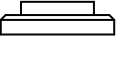
Zero Fan Taste (Lüfter-Taste)	Zero RPM Fan Modus	Beschreibung
 Unbedrückt	On (Ein) (Standard)	Der PSU-Lüfter stoppt, wenn die Systemlast unter den festgelegten Wert fällt.
 Gedrückt	OFF (Aus)	Der PSU-Lüfter läuft ständig.

Wichtig

Der Zero-RPM-Lüftermodus ist standardmäßig aktiv. Drücken Sie die Taste, um es zu deaktivieren.

Table des matières

Caractéristiques	2
Dimensions	3
Nombre de connecteurs d'alimentation	4
Connecteurs détachables.....	5
Connectique et longueur des câbles	6
Installation du câble PCIe 16 broches	8
Bouton Zero Fan	9

Caractéristiques

1000 W					
Tension	+5 V	+3,3 V	+12 V	-12 V	+5 Vsb
Charge maximale	22,0 A	22,0 A	83,5 A	0,3 A	3,0 A
Charge minimale	0,0 A	0,0 A	0,0 A	0,0 A	0,0 A
Puissance combinée (+5 V et +3,3 V)	120 W		1000 W	3,6 W	15,0 W
Puissance totale	1000 W				
Régulation	± 5 %	± 5 %	± 5 %	± 5 %	± 5 %
Ondulation et bruit	30 mVp-p	30 mVp-p	50 mVp-p	40 mVp-p	40 mVp-p

850 W					
Tension	+5 V	+3,3 V	+12 V	-12 V	+5 Vsb
Charge maximale	22,0 A	22,0 A	70,8 A	0,3 A	3,0 A
Charge minimale	0,0 A	0,0 A	0,0 A	0,0 A	0,0 A
Puissance combinée (+5 V et +3,3 V)	120 W		850 W	3,6 W	15,0 W
Puissance totale	850 W				
Régulation	± 5 %	± 5 %	± 5 %	± 5 %	± 5 %
Ondulation et bruit	30 mVp-p	30 mVp-p	50 mVp-p	40 mVp-p	40 mVp-p

750 W					
Tension	+5 V	+3,3 V	+12 V	-12 V	+5 Vsb
Charge maximale	22,0 A	22,0 A	62,5 A	0,3 A	3,0 A
Charge minimale	0,0 A	0,0 A	0,0 A	0,0 A	0,0 A
Puissance combinée (+5 V et +3,3 V)	120 W		750 W	3,6 W	15,0 W
Puissance totale	750 W				
Régulation	± 5 %	± 5 %	± 5 %	± 5 %	± 5 %
Ondulation et bruit	30 mVp-p	30 mVp-p	50 mVp-p	40 mVp-p	40 mVp-p

Dimensions

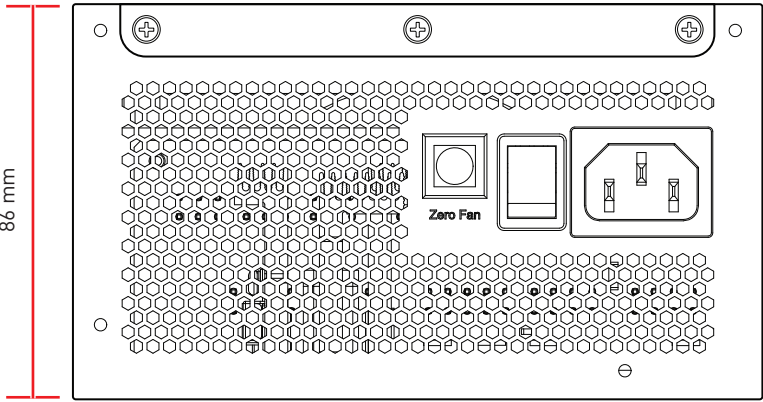
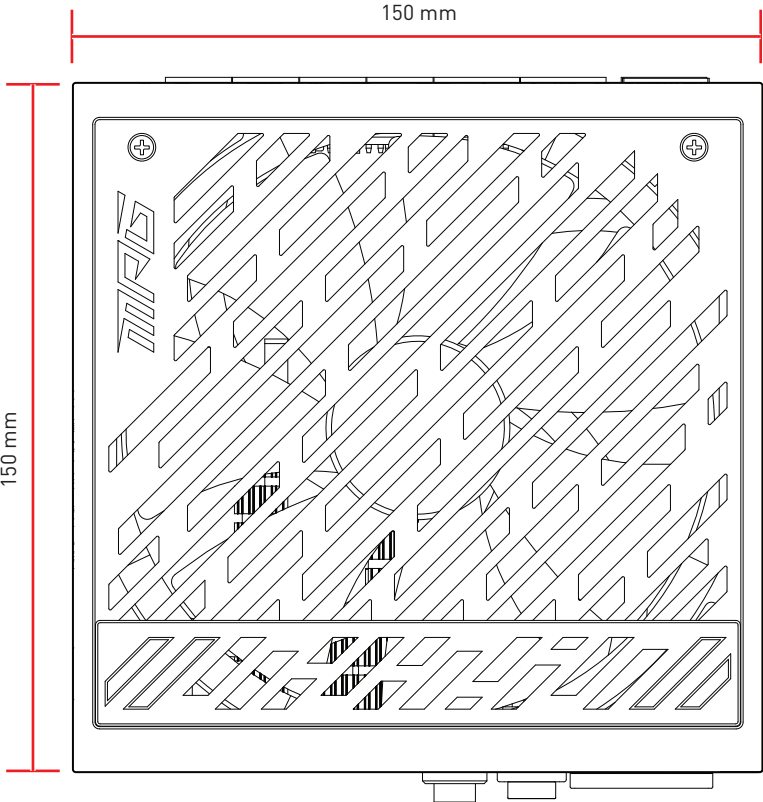

Nombre de connecteurs d'alimentation

Connecteurs d'alimentation	A1000G PCIE5	A850G PCIE5	A750G PCIE5
ATX12V (Carte mère) 20+4 broches	1	1	1
PCIe 16 broches	1	1	1
EPS12V (CPU) 4+4 broches	2	2	2
PCIe (VGA) 6+2 broches	6	6	6
SATA 15 broches	12	8	8
Périphérique (PATA) 4 broches	4	4	4
FDD 4 broches	1	1	1

Connecteurs détachables

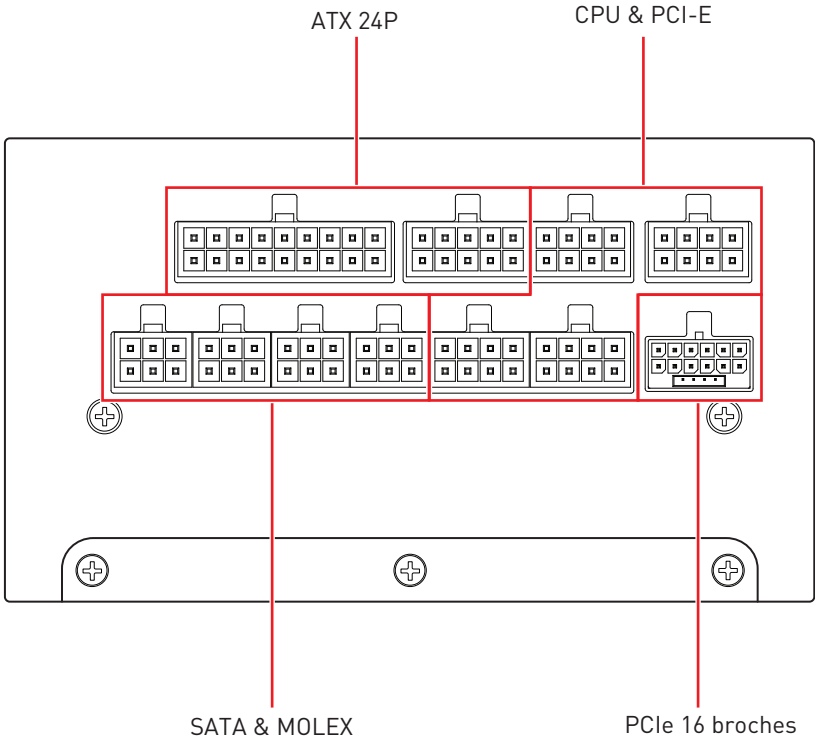

Connectique et longueur des câbles

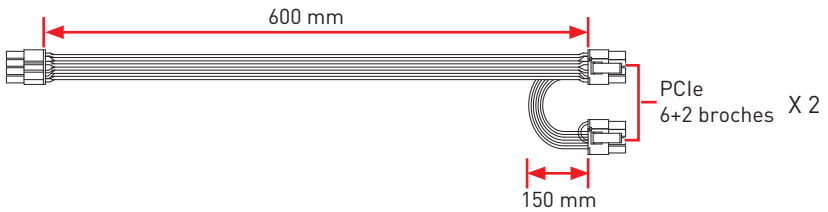
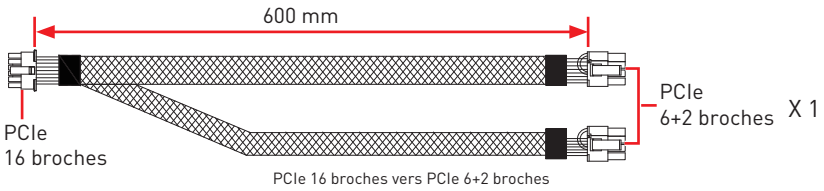
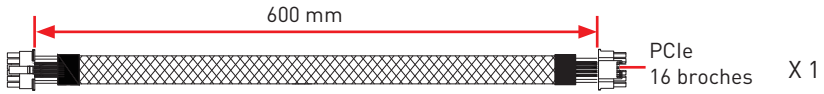
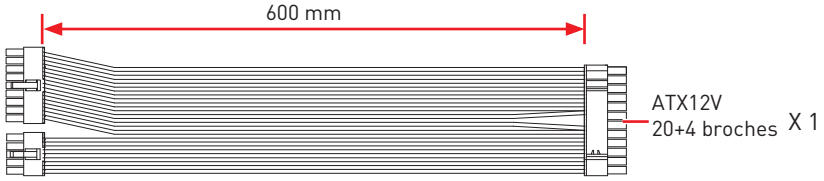

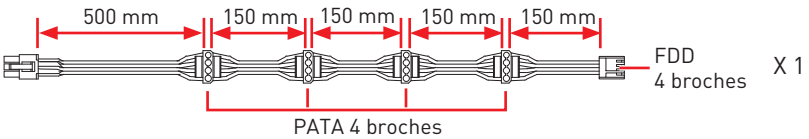
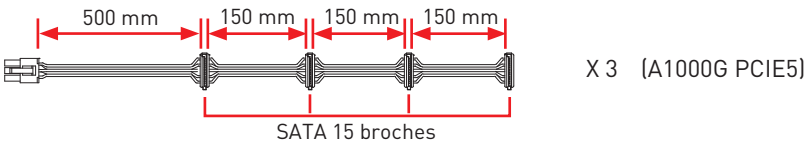
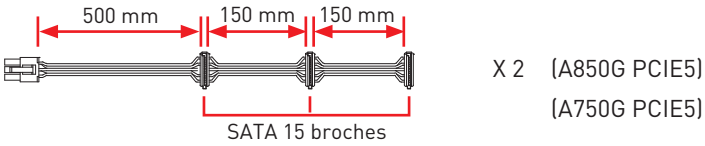
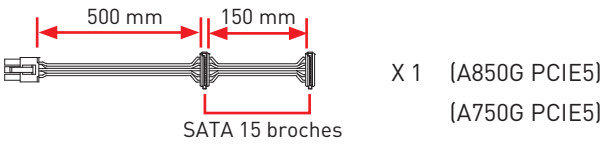

Installation du câble PCIe 16 broches

 **Attention**

Veillez totalement insérer le câble avant de l'utiliser.

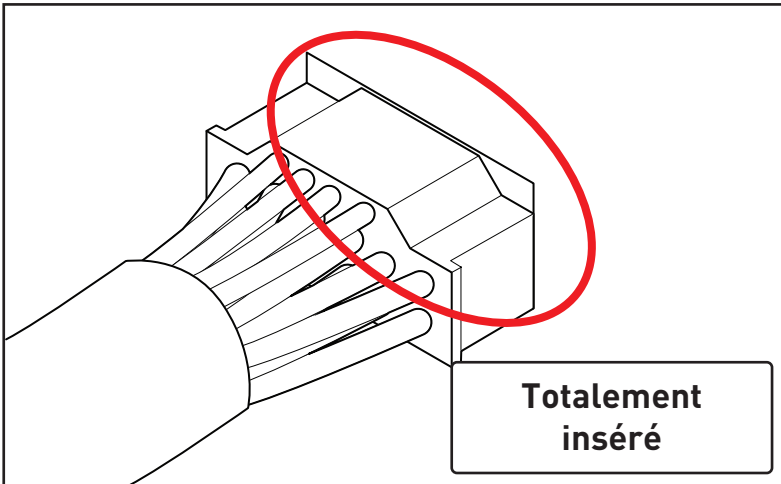
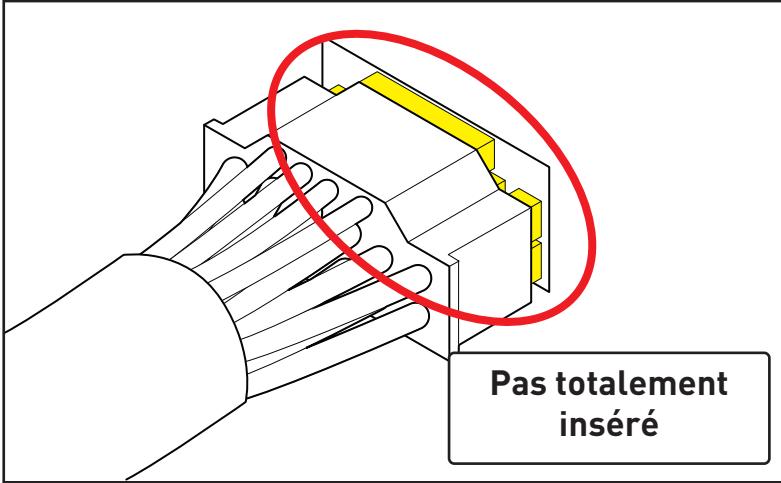

Bouton Zero Fan

Appuyez sur le bouton Zero Fan pour activer ou désactiver le **Mode Zero RPM Fan**.

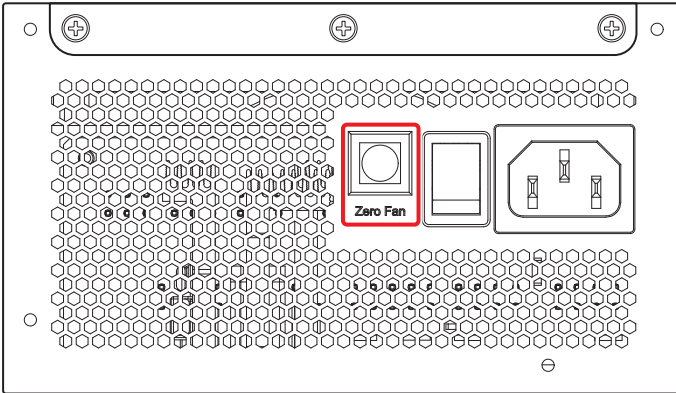

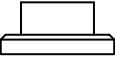
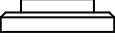
Bouton Zero Fan	Mode Zero RPM Fan	Description
 Position relâchée	Activer (Défaut)	Le ventilateur du bloc d'alimentation s'arrête lorsque la charge du système passe en dessous du niveau désigné.
 Position enfoncée	Désactiver	Le ventilateur du bloc d'alimentation fonctionne constamment.

Important

Le mode Zero RPM Fan est activé par défaut. Appuyez sur le bouton pour le désactiver.

Содержание

Спецификация.....	2
Размеры.....	3
Кол-во силовых соединителей.....	4
Кабельные интерфейсы.....	5
Подключение и длина кабелей.....	6
Подключение кабеля PCIe 16 Pin.....	8
Кнопка Zero Fan.....	9

Спецификация

1000W					
Напряжение	+5V	+3.3V	+12V	-12V	+5Vsb
Максимальная нагрузка	22.0A	22.0A	83.5A	0.3A	3.0A
Минимальная нагрузка	0.0A	0.0A	0.0A	0.0A	0.0A
Комбинированная мощность (+5V&+3.3V)	120W		1000W	3.6W	15.0W
Общая мощность	1000W				
Регулирование	± 5%	± 5%	± 5%	± 5%	± 5%
Пульсации и шумы	30mVp-p	30mVp-p	50mVp-p	40mVp-p	40mVp-p

850W					
Напряжение	+5V	+3.3V	+12V	-12V	+5Vsb
Максимальная нагрузка	22.0A	22.0A	70.8A	0.3A	3.0A
Минимальная нагрузка	0.0A	0.0A	0.0A	0.0A	0.0A
Комбинированная мощность (+5V&+3.3V)	120W		850W	3.6W	15.0W
Общая мощность	850W				
Регулирование	± 5%	± 5%	± 5%	± 5%	± 5%
Пульсации и шумы	30mVp-p	30mVp-p	50mVp-p	40mVp-p	40mVp-p

750W					
Напряжение	+5V	+3.3V	+12V	-12V	+5Vsb
Максимальная нагрузка	22.0A	22.0A	62.5A	0.3A	3.0A
Минимальная нагрузка	0.0A	0.0A	0.0A	0.0A	0.0A
Комбинированная мощность (+5V&+3.3V)	120W		750W	3.6W	15.0W
Общая мощность	750W				
Регулирование	± 5%	± 5%	± 5%	± 5%	± 5%
Пульсации и шумы	30mVp-p	30mVp-p	50mVp-p	40mVp-p	40mVp-p

Размеры

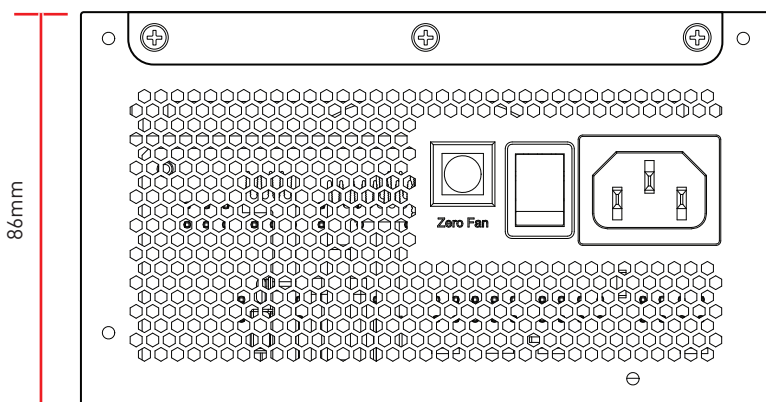
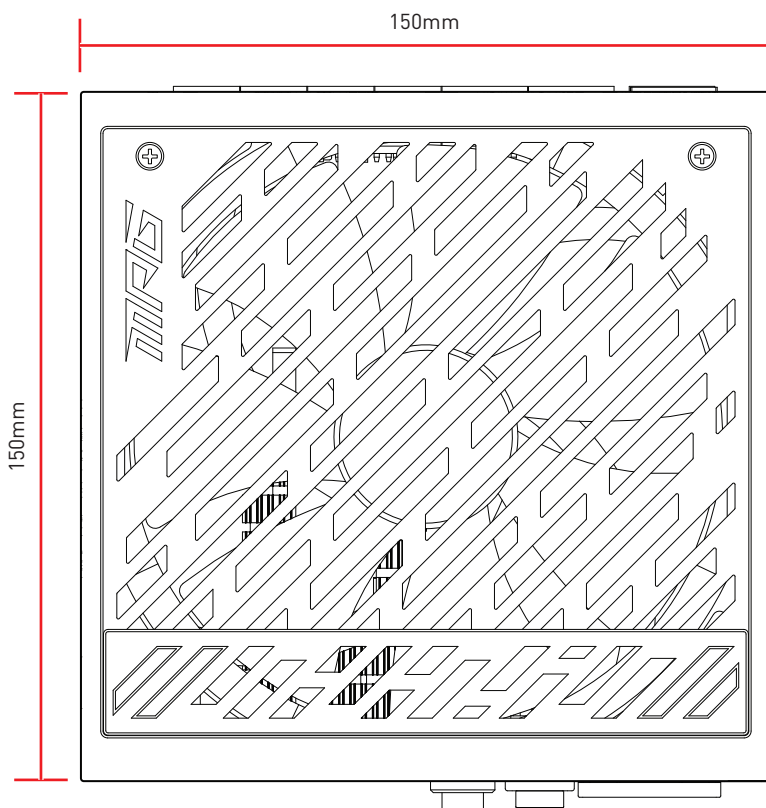

Кол-во силовых соединителей

Разъемы питания	A1000G PCIE5	A850G PCIE5	A750G PCIE5
ATX12V (Материнская плата) 20+4 pin	1	1	1
PCIe 16 pin	1	1	1
EPS12V (CPU) 4+4 pin	2	2	2
PCIe (VGA) 6+2 pin	6	6	6
SATA 15 pin	12	8	8
Периферийные устройства (PATA) 4 pin	4	4	4
FDD 4 pin	1	1	1

Кабельные интерфейсы

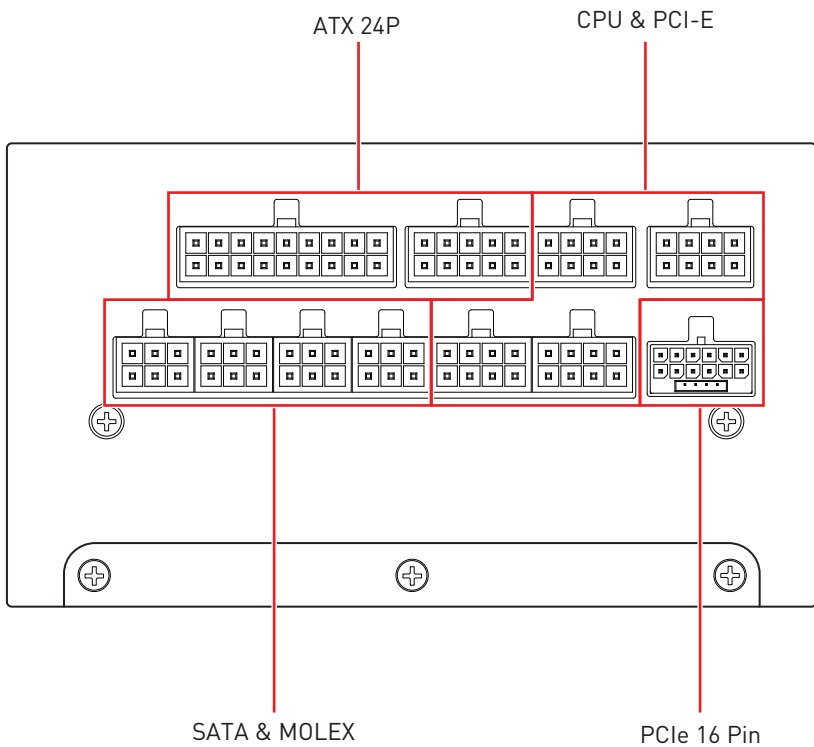

Подключение и длина кабелей

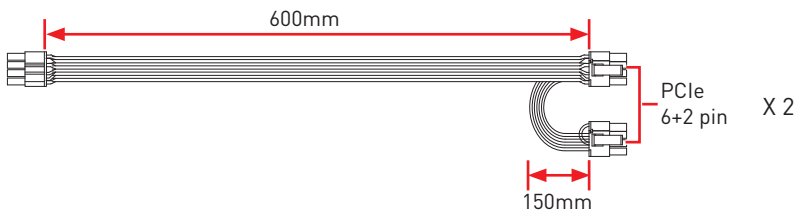
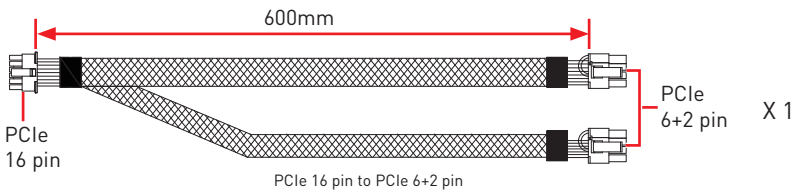
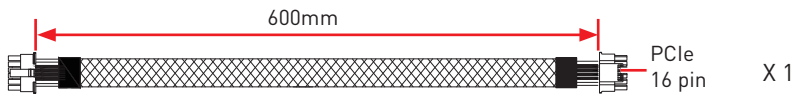
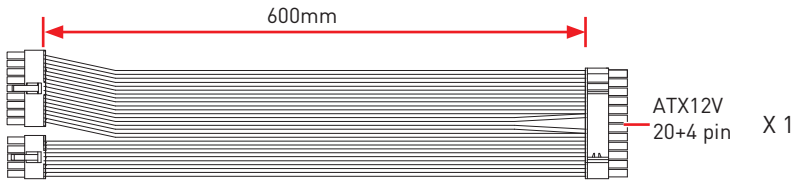

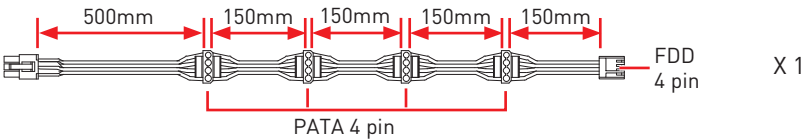
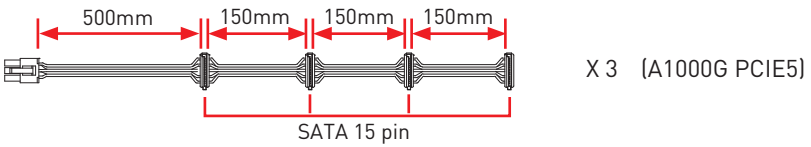
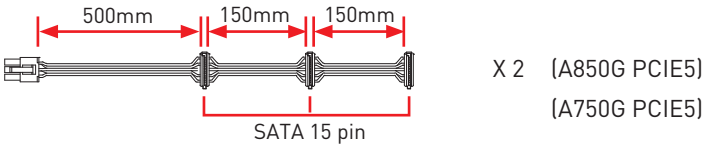
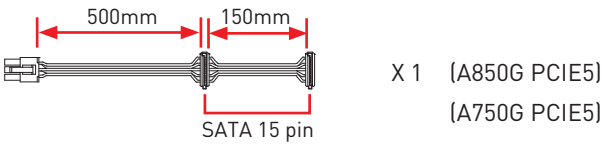
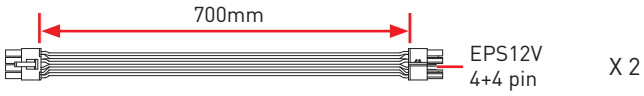

Подключение кабеля PCIe 16 Pin

! **ВНИМАНИЕ!**

Перед использованием убедитесь, что кабель полностью вставлен.

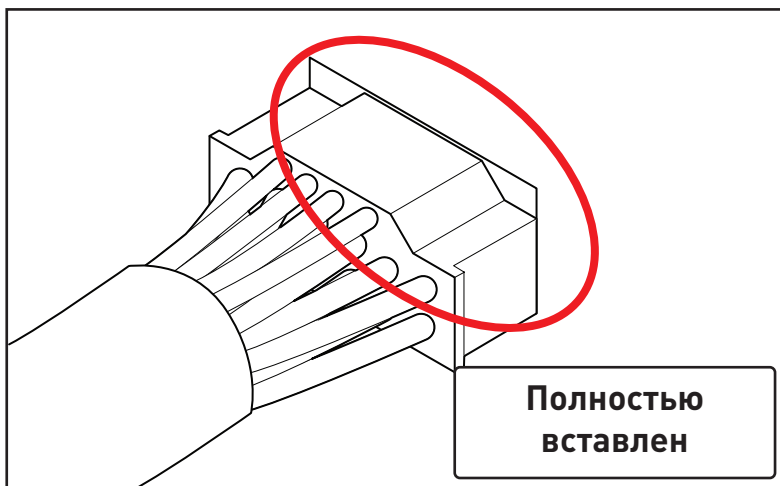
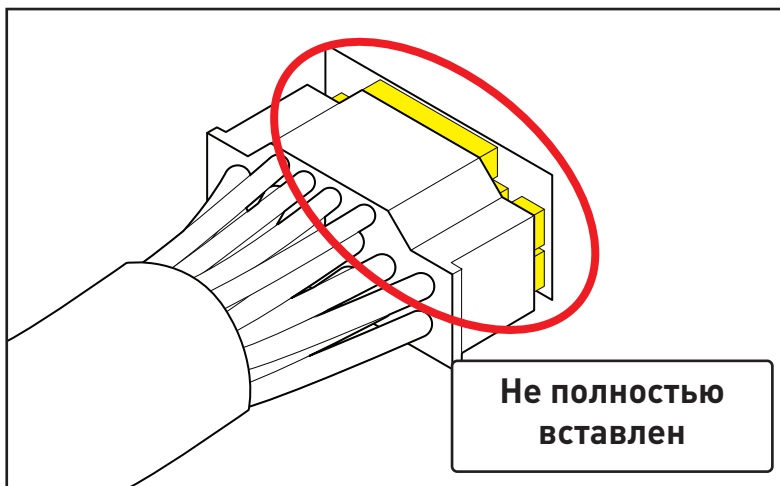

Кнопка Zero Fan

Нажмите кнопку Zero Fan, чтобы включить или выключить режим **Zero RPM Fan**.

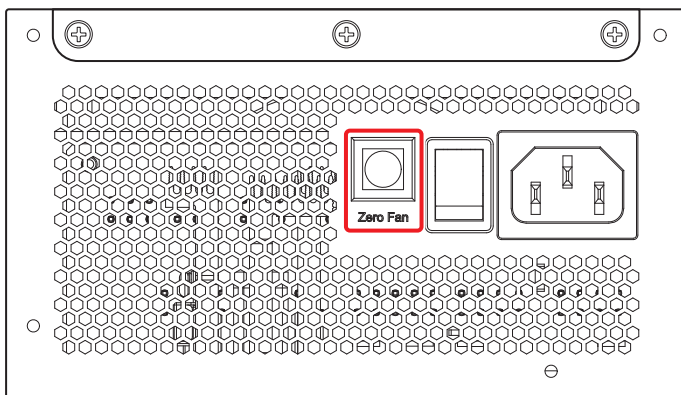

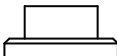
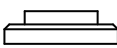
Кнопка Zero Fan	Режим Zero RPM Fan	Описание
 Кнопка не нажата	Вкл. (По умолчанию)	Вентилятор блока питания останавливается, когда нагрузка на систему падает ниже указанного уровня.
 Кнопка нажата	Выкл.	Вентилятор блока питания работает непрерывно.

Внимание!

Режим Zero RPM Fan по умолчанию включен. Для его отключения нажмите кнопку.

目次

仕様.....	2
外形寸法.....	3
電源コネクタ数.....	4
電源コネクタ配置図.....	5
コネクタ & ケーブル長さ.....	6
PCIe 16ピンケーブルの取り付け.....	8
Zero Fanボタン.....	9

仕様

1000W					
電圧	+5V	+3.3V	+12V	-12V	+5Vsb
最大電流	22.0A	22.0A	83.5A	0.3A	3.0A
最小電流	0.0A	0.0A	0.0A	0.0A	0.0A
最大電力 [+5V&+3.3V]	120W		1000W	3.6W	15.0W
最大総合電力	1000W				
レギュレーション	± 5%	± 5%	± 5%	± 5%	± 5%
リップルノイズ	30mVp-p	30mVp-p	50mVp-p	40mVp-p	40mVp-p

850W					
電圧	+5V	+3.3V	+12V	-12V	+5Vsb
最大電流	22.0A	22.0A	70.8A	0.3A	3.0A
最小電流	0.0A	0.0A	0.0A	0.0A	0.0A
最大電力 [+5V&+3.3V]	120W		850W	3.6W	15.0W
最大総合電力	850W				
レギュレーション	± 5%	± 5%	± 5%	± 5%	± 5%
リップルノイズ	30mVp-p	30mVp-p	50mVp-p	40mVp-p	40mVp-p

750W					
電圧	+5V	+3.3V	+12V	-12V	+5Vsb
最大電流	22.0A	22.0A	62.5A	0.3A	3.0A
最小電流	0.0A	0.0A	0.0A	0.0A	0.0A
最大電力 [+5V&+3.3V]	120W		750W	3.6W	15.0W
最大総合電力	750W				
レギュレーション	± 5%	± 5%	± 5%	± 5%	± 5%
リップルノイズ	30mVp-p	30mVp-p	50mVp-p	40mVp-p	40mVp-p

外形寸法

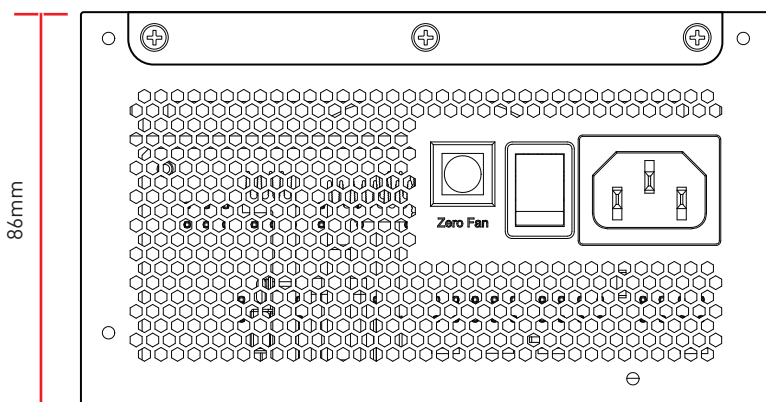
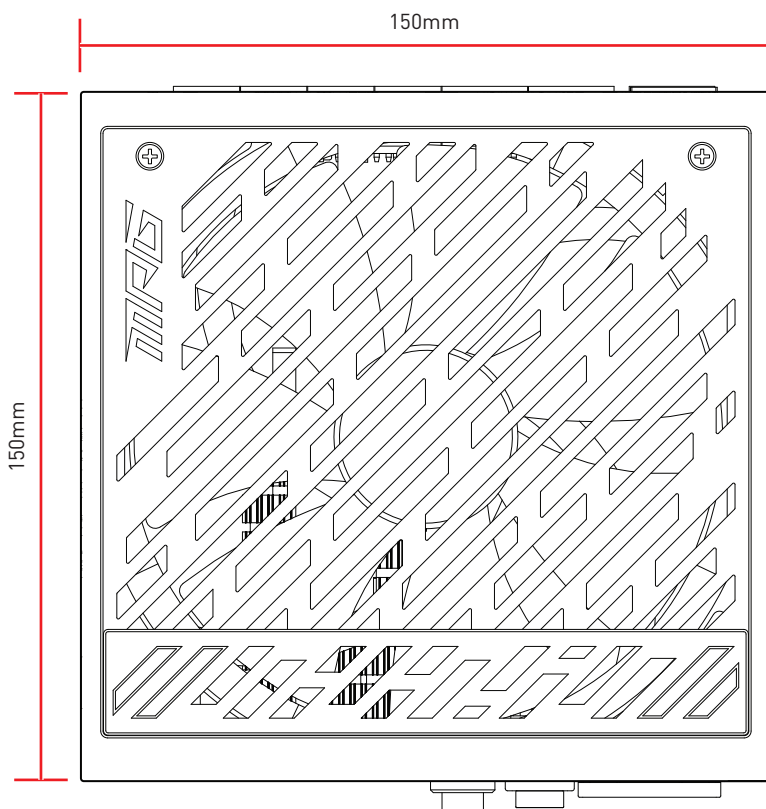

電源コネクタ数

電源コネクタ	A1000G PCIE5	A850G PCIE5	A750G PCIE5
ATX12V (マザーボード) 20+4ピン	1	1	1
PCIe 16ピン	1	1	1
EPS12V (CPU) 4+4ピン	2	2	2
PCIe (VGA) 6+2ピン	6	6	6
SATA 15ピン	12	8	8
ペリフェラル (PATA) 4ピン	4	4	4
FDD 4ピン	1	1	1

電源コネクタ配置図

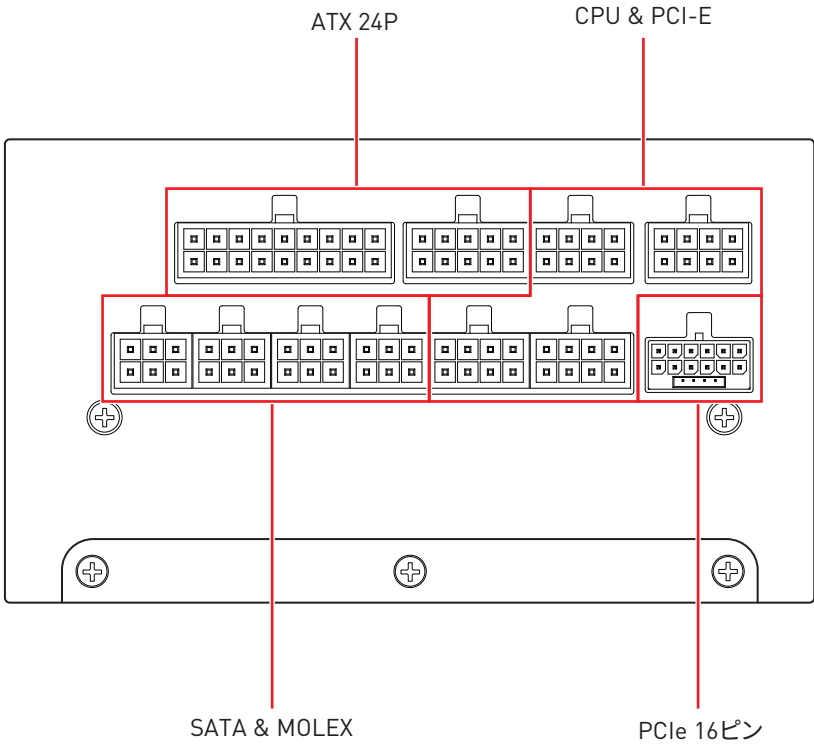

コネクタ & ケーブル長さ

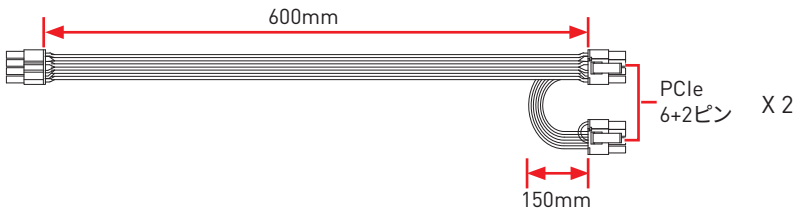
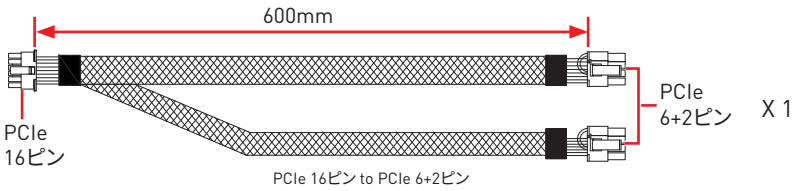
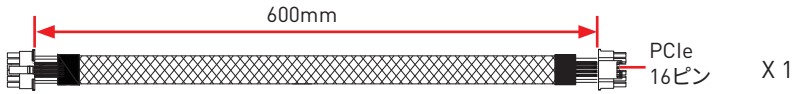
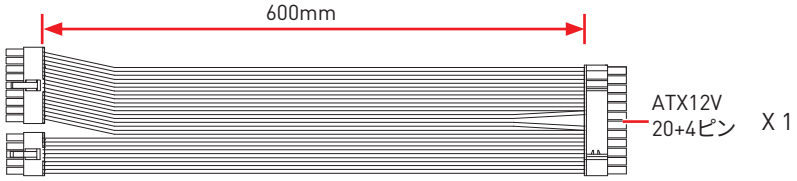

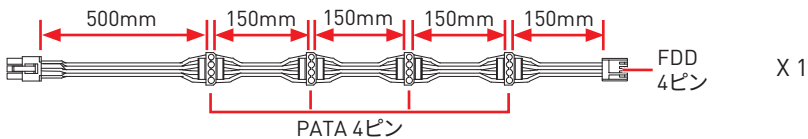
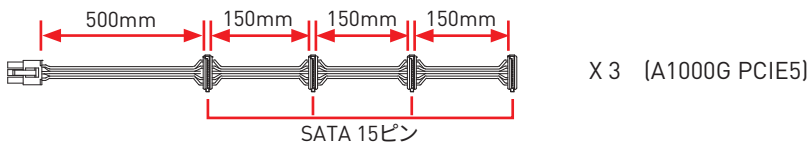
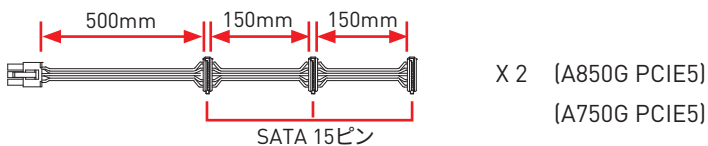
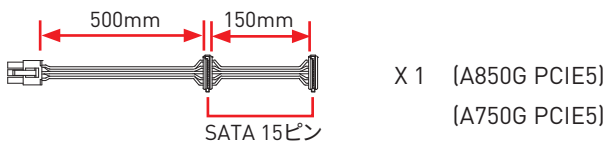

PCIe 16ピンケーブルの取り付け



警告

ケーブルを奥までしっかりと挿し込んでください。

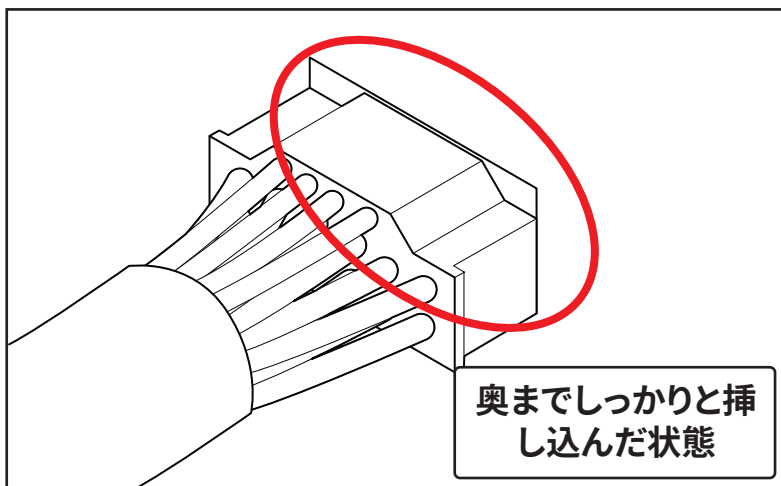
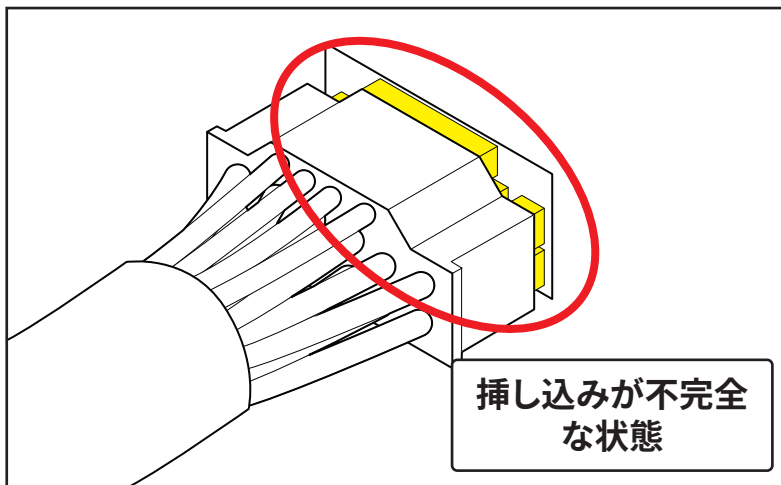

Zero Fanボタン

Zero Fanボタンを押して、Zero RPM Fan ModeのON/OFFを切り替えます。

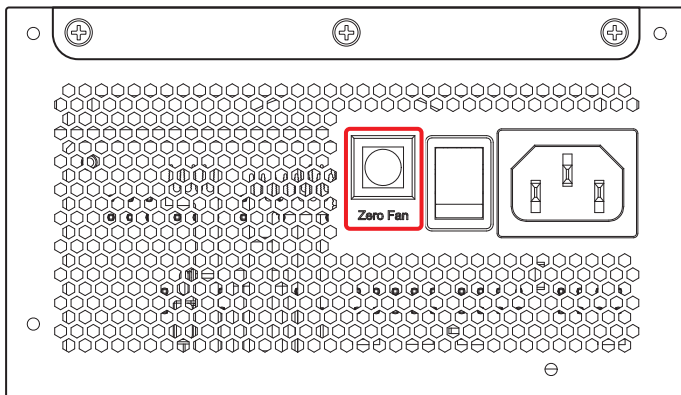

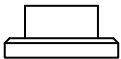
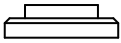
Zero Fanボタン	Zero RPM Fan Mode	説明
 押されていない 状態	ON (デフォルト)	システム負荷が指定レベル以下になると、PSUファンが停止します。
 押された状態	OFF	PSUファンが常時回転します。

注意

デフォルトでは、Zero RPM Fan ModeがONに設定されています。ボタンを押すと、この機能がOFFになります。

Contents

- Specifications.....2
- Dimensions3
- Number of Power Connectors.....4
- Detachable Connectors5
- Connectivity and Cable Lengths6
- PCIe 16 Pin Cable Installation8
- Zero Fan Button9

사양

1000W					
전압	+5V	+3.3V	+12V	-12V	+5Vsb
최대 하중	22.0A	22.0A	83.5A	0.3A	3.0A
최소 하중	0.0A	0.0A	0.0A	0.0A	0.0A
복합 전원 (+5V&+3.3V)	120W		1000W	3.6W	15.0W
토탈 전원	1000W				
규제	± 5%	± 5%	± 5%	± 5%	± 5%
리플 & 노이즈	30mVp-p	30mVp-p	50mVp-p	40mVp-p	40mVp-p

850W					
전압	+5V	+3.3V	+12V	-12V	+5Vsb
최대 하중	22.0A	22.0A	70.8A	0.3A	3.0A
최소 하중	0.0A	0.0A	0.0A	0.0A	0.0A
복합 전원	120W		850W	3.6W	15.0W
토탈 전원	850W				
규제	± 5%	± 5%	± 5%	± 5%	± 5%
리플 & 노이즈	30mVp-p	30mVp-p	50mVp-p	40mVp-p	40mVp-p

750W					
전압	+5V	+3.3V	+12V	-12V	+5Vsb
최대 하중	22.0A	22.0A	62.5A	0.3A	3.0A
최소 하중	0.0A	0.0A	0.0A	0.0A	0.0A
복합 전원 (+5V&+3.3V)	120W		750W	3.6W	15.0W
토탈 전원	750W				
규제	± 5%	± 5%	± 5%	± 5%	± 5%
리플 & 노이즈	30mVp-p	30mVp-p	50mVp-p	40mVp-p	40mVp-p

치수

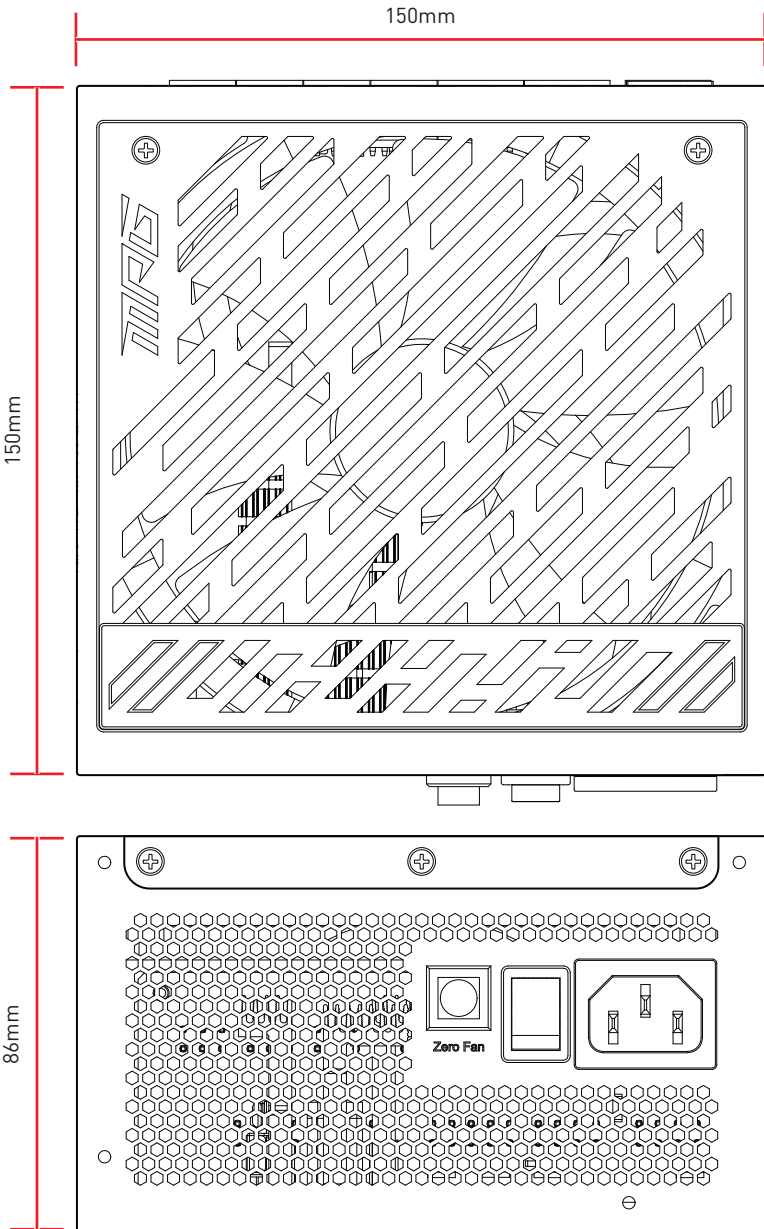

전원 커넥터 수량

전원 커넥터	A1000G PCIE5	A850G PCIE5	A750G PCIE5
ATX12V (메인보드) 20+4 핀	1	1	1
PCIe 16 핀	1	1	1
EPS12V (CPU) 4+4 핀	2	2	2
PCIe (VGA) 6+2 핀	6	6	6
SATA 15 핀	12	8	8
주변기기 (PATA) 4핀	4	4	4
FDD 4 핀	1	1	1

탈착식 커넥터

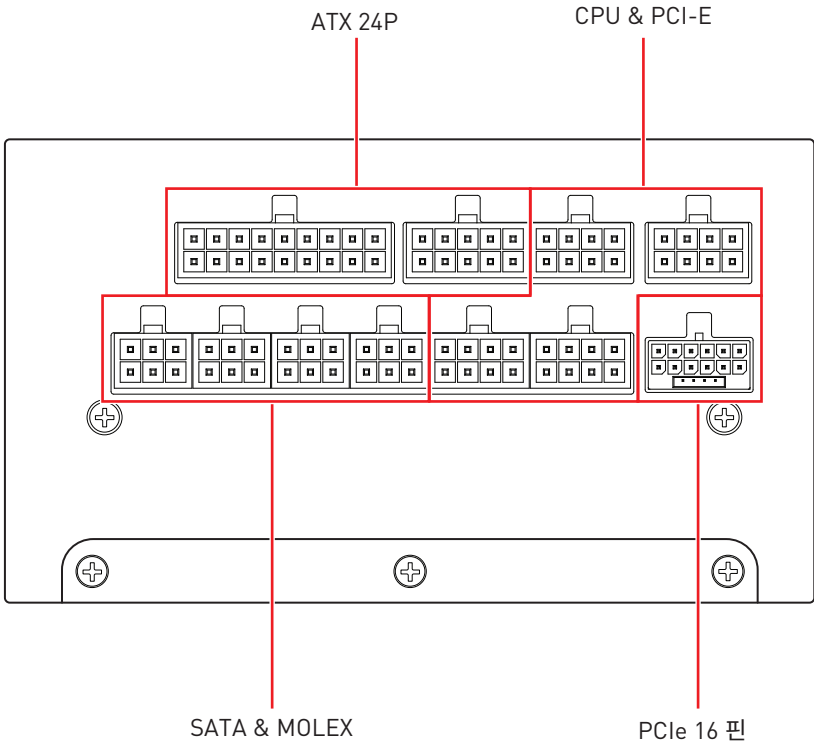

연결 및 케이블 길이

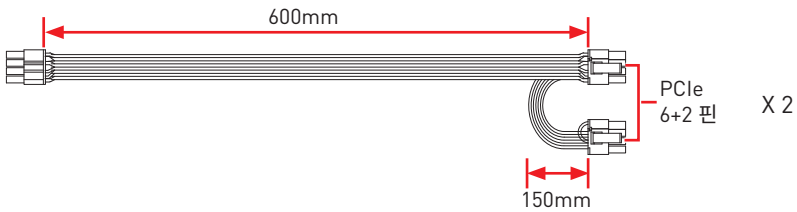
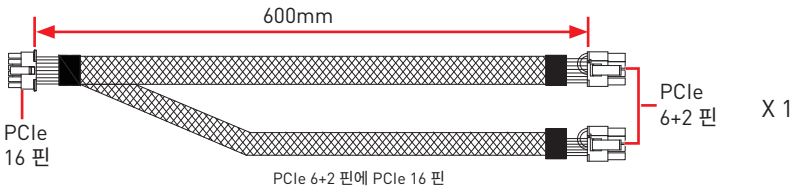
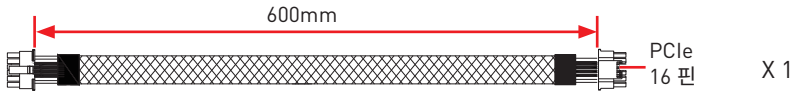
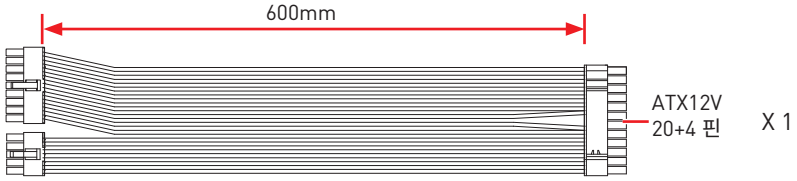

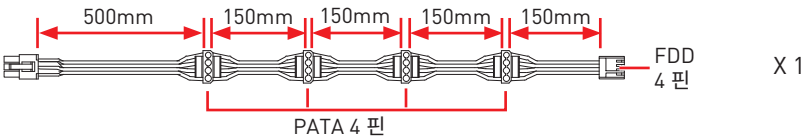
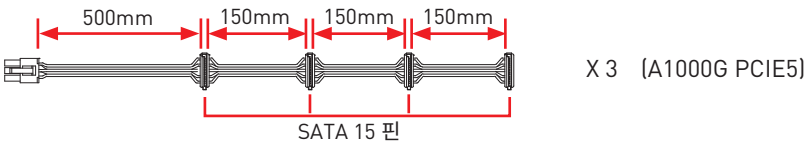
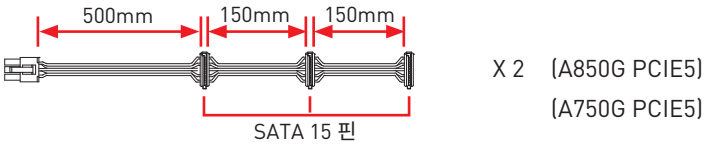
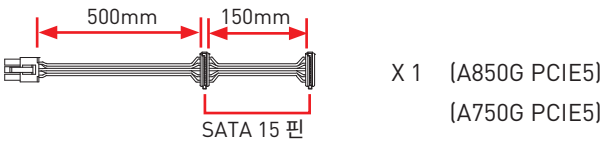

PCIe 16 핀 케이블 설치



주의

사용하기 전에 케이블을 완전히 삽입하십시오.

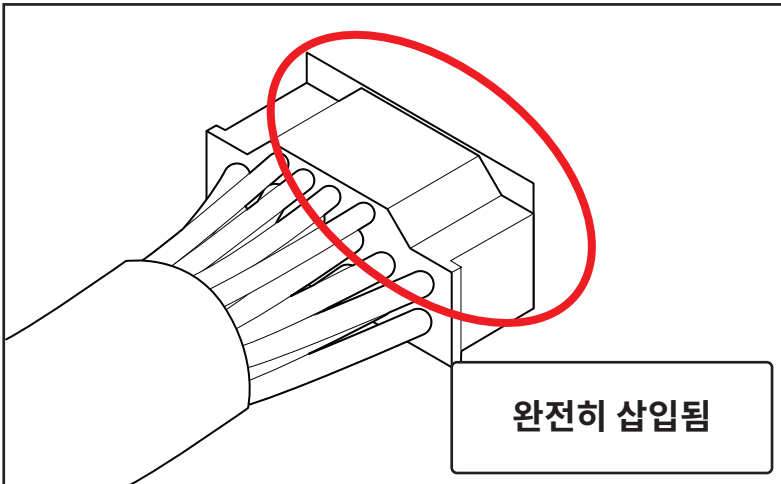
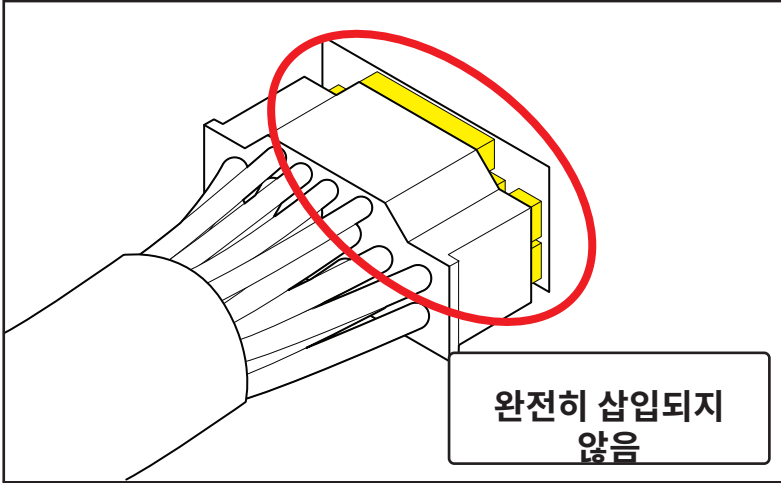

제로 팬 버튼

제로 팬 버튼을 눌러 제로 RPM 팬 모드를 켜거나 끕니다.

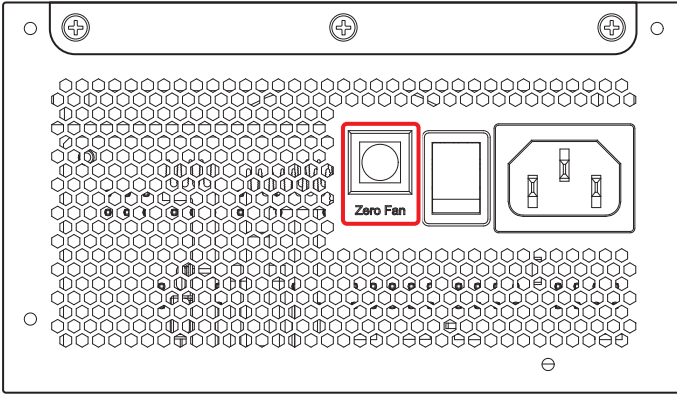

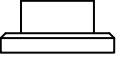
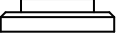
제로 팬 버튼	제로 RPM 팬 모드	설명
 버튼을 누르지 않음	켜기 (기본)	시스템 부하가 지정된 수준 아래로 떨어지면 PSU 팬이 중지됩니다.
 버튼을 누름	끄기	PSU 팬이 계속 작동합니다.

중요사항

제로 RPM 팬 모드는 기본적으로 활성화되어 있습니다. 버튼을 눌러 비활성화하세요.

目錄

規格.....	2
尺寸.....	3
電源接頭數量.....	4
可拆卸接頭.....	5
連接頭和電纜長度.....	6
PCIe 16 針線材安裝.....	8
Zero Fan 按鈕.....	9

規格

1000W					
電壓	+5V	+3.3V	+12V	-12V	+5Vsb
最大負載	22.0A	22.0A	83.5A	0.3A	3.0A
最小負載	0.0A	0.0A	0.0A	0.0A	0.0A
結合功率 (+5V&+3.3V)	120W		1000W	3.6W	15.0W
總功率	1000W				
調節	± 5%	± 5%	± 5%	± 5%	± 5%
紋波雜訊	30mVp-p	30mVp-p	50mVp-p	40mVp-p	40mVp-p

850W					
電壓	+5V	+3.3V	+12V	-12V	+5Vsb
最大負載	22.0A	22.0A	70.8A	0.3A	3.0A
最小負載	0.0A	0.0A	0.0A	0.0A	0.0A
結合功率 (+5V&+3.3V)	120W		850W	3.6W	15.0W
總功率	850W				
調節	± 5%	± 5%	± 5%	± 5%	± 5%
紋波雜訊	30mVp-p	30mVp-p	50mVp-p	40mVp-p	40mVp-p

750W					
電壓	+5V	+3.3V	+12V	-12V	+5Vsb
最大負載	22.0A	22.0A	62.5A	0.3A	3.0A
最小負載	0.0A	0.0A	0.0A	0.0A	0.0A
結合功率 (+5V&+3.3V)	120W		750W	3.6W	15.0W
總功率	750W				
調節	± 5%	± 5%	± 5%	± 5%	± 5%
紋波雜訊	30mVp-p	30mVp-p	50mVp-p	40mVp-p	40mVp-p

尺寸

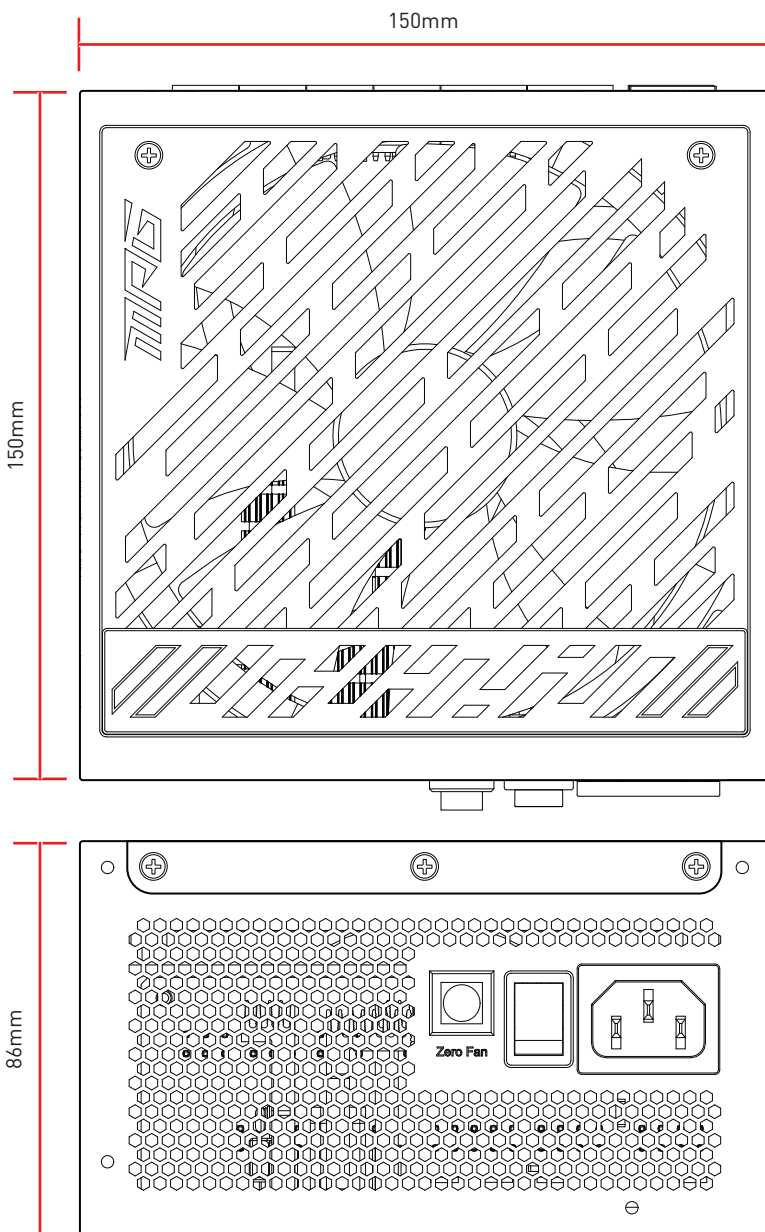

電源接頭數量

電源接頭	A1000G PCIE5	A850G PCIE5	A750G PCIE5
ATX12V (主機板) 20+4 針	1	1	1
PCIe 16 針	1	1	1
EPS12V (CPU) 4+4 針	2	2	2
PCIe (VGA) 6+2 針	6	6	6
SATA 15 針	12	8	8
週邊設備 (PATA) 4 針	4	4	4
FDD 4 針	1	1	1

可拆卸接頭

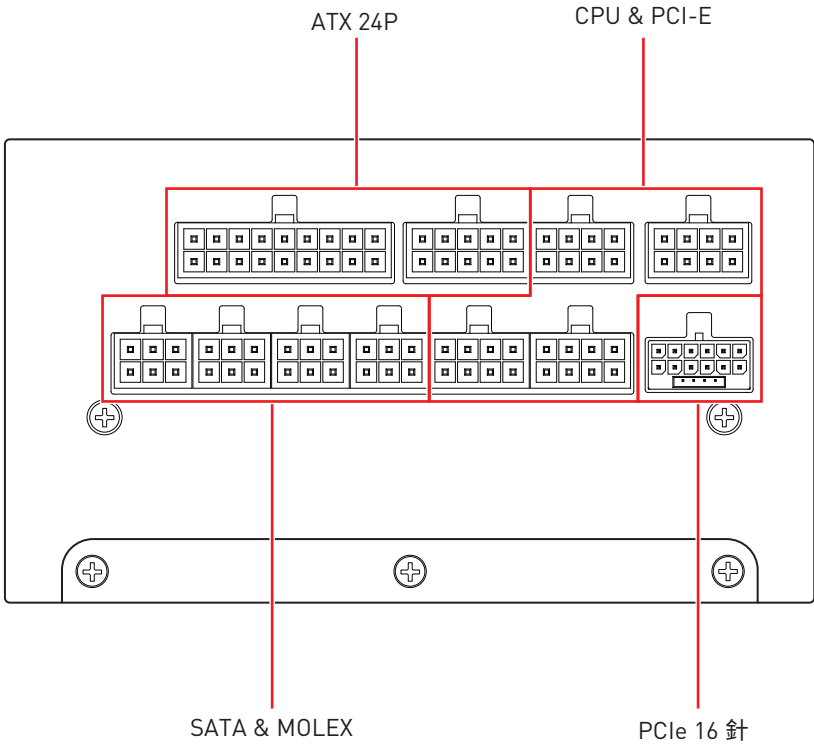

連接頭和電纜長度

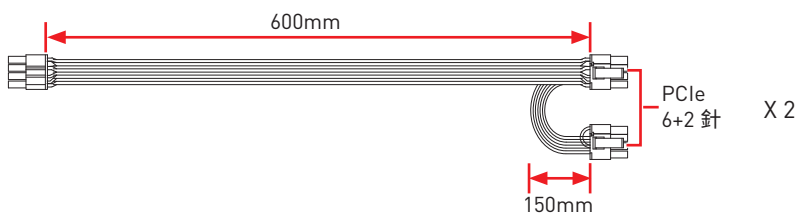
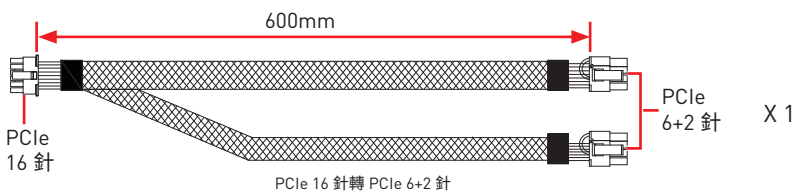
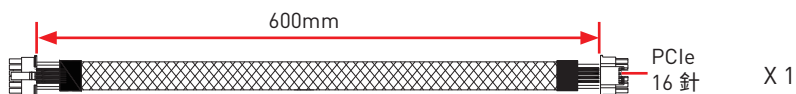
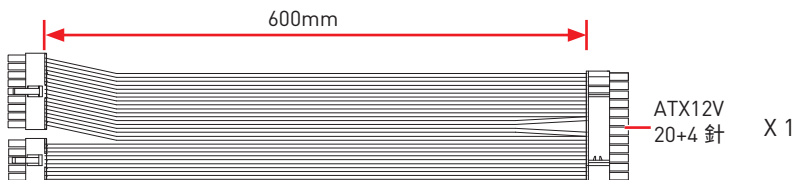

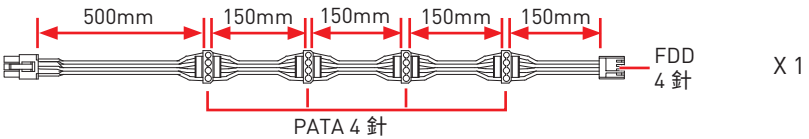
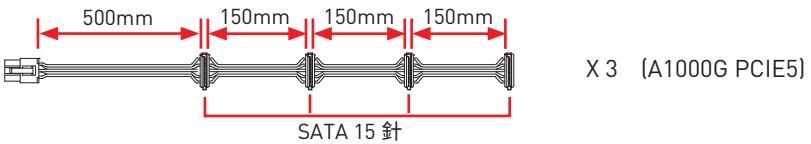
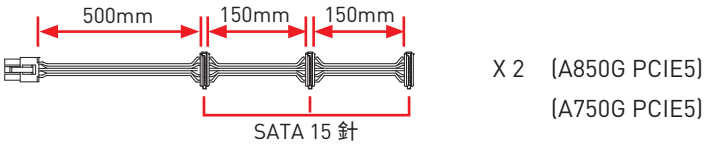
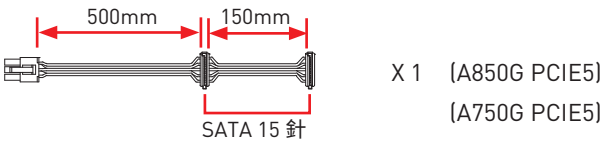

PCIe 16 針線材安裝



警告

使用前請確實插好插頭。

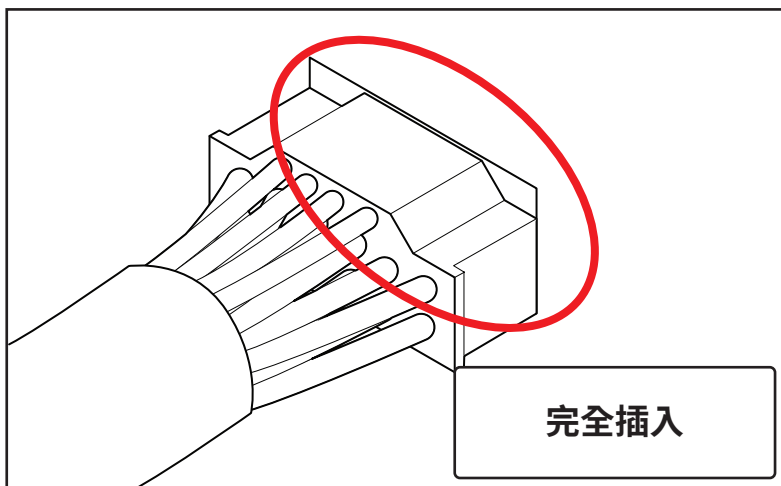
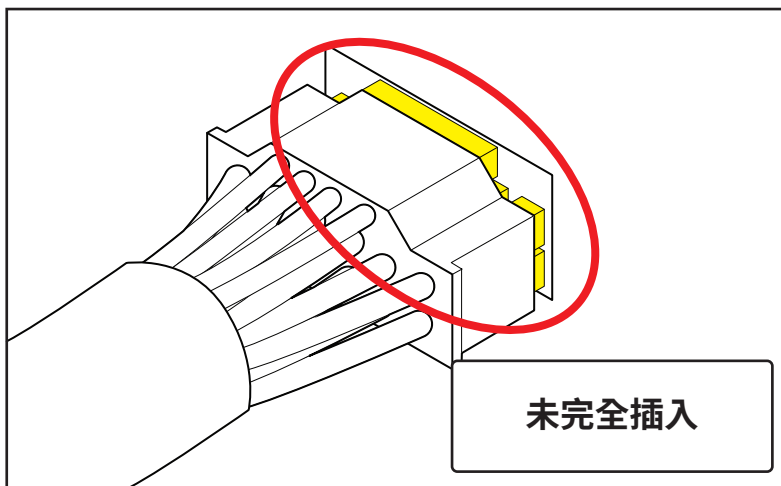

Zero Fan 按鈕

按壓 Zero Fan 按鈕以開啓或關閉 Zero RPM Fan 模式。

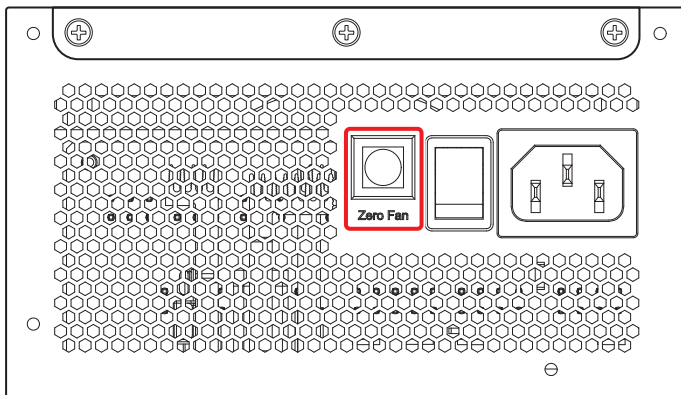

Zero Fan 按鈕	Zero RPM Fan 模式	說明
 彈起	開啓 (預設)	當系統負載低於特定水平時，電源風扇停止運轉。
 壓下	關閉	電源風扇持續運轉。

重要

Zero RPM Fan 模式預設為開啓狀態；按壓按鈕關閉。

目录

产品规格.....	2
尺寸.....	3
电源接口数量.....	4
可拆卸接口.....	5
接口和电缆的长度.....	6
PCIe 16 针电缆安装.....	8
Zero Fan 按钮.....	9

产品规格

1000W					
电压	+5V	+3.3V	+12V	-12V	+5Vsb
最大负载	22.0A	22.0A	83.5A	0.3A	3.0A
最小负载	0.0A	0.0A	0.0A	0.0A	0.0A
组合功率 (+5V&+3.3V)	120W		1000W	3.6W	15.0W
总功率	1000W				
调节	± 5%	± 5%	± 5%	± 5%	± 5%
波纹噪声	30mVp-p	30mVp-p	50mVp-p	40mVp-p	40mVp-p

850W					
电压	+5V	+3.3V	+12V	-12V	+5Vsb
最大负载	22.0A	22.0A	70.8A	0.3A	3.0A
最小负载	0.0A	0.0A	0.0A	0.0A	0.0A
组合功率 (+5V&+3.3V)	120W		850W	3.6W	15.0W
总功率	850W				
调节	± 5%	± 5%	± 5%	± 5%	± 5%
波纹噪声	30mVp-p	30mVp-p	50mVp-p	40mVp-p	40mVp-p

750W					
电压	+5V	+3.3V	+12V	-12V	+5Vsb
最大负载	22.0A	22.0A	62.5A	0.3A	3.0A
最小负载	0.0A	0.0A	0.0A	0.0A	0.0A
组合功率 (+5V&+3.3V)	120W		750W	3.6W	15.0W
总功率	750W				
调节	± 5%	± 5%	± 5%	± 5%	± 5%
波纹噪声	30mVp-p	30mVp-p	50mVp-p	40mVp-p	40mVp-p

尺寸

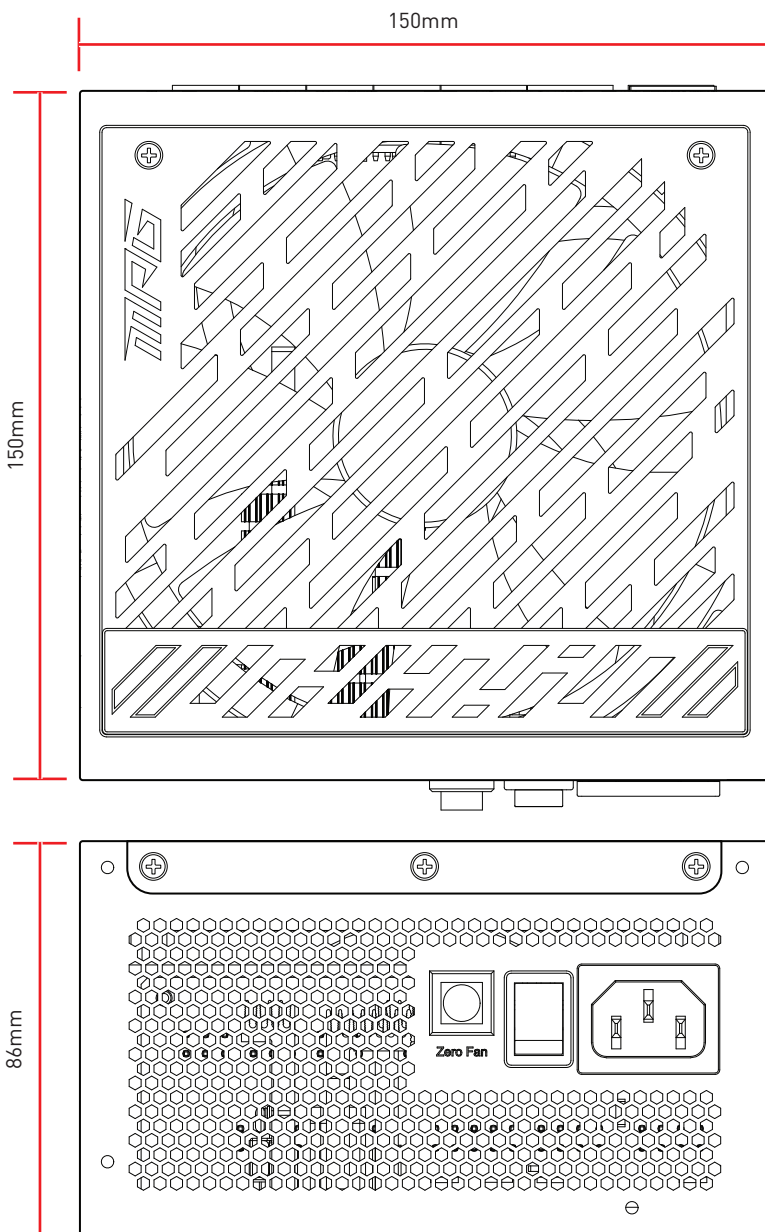

电源接口数量

电源接口	A1000G PCIE5	A850G PCIE5	A750G PCIE5
ATX12V (主板) 20+4 针	1	1	1
PCIe 16 针	1	1	1
EPS12V (CPU) 4+4 针	2	2	2
PCIe (VGA) 6+2 针	6	6	6
SATA 15 针	12	8	8
外围设备 (PATA) 4 针	4	4	4
FDD 4 针	1	1	1

可拆卸接口

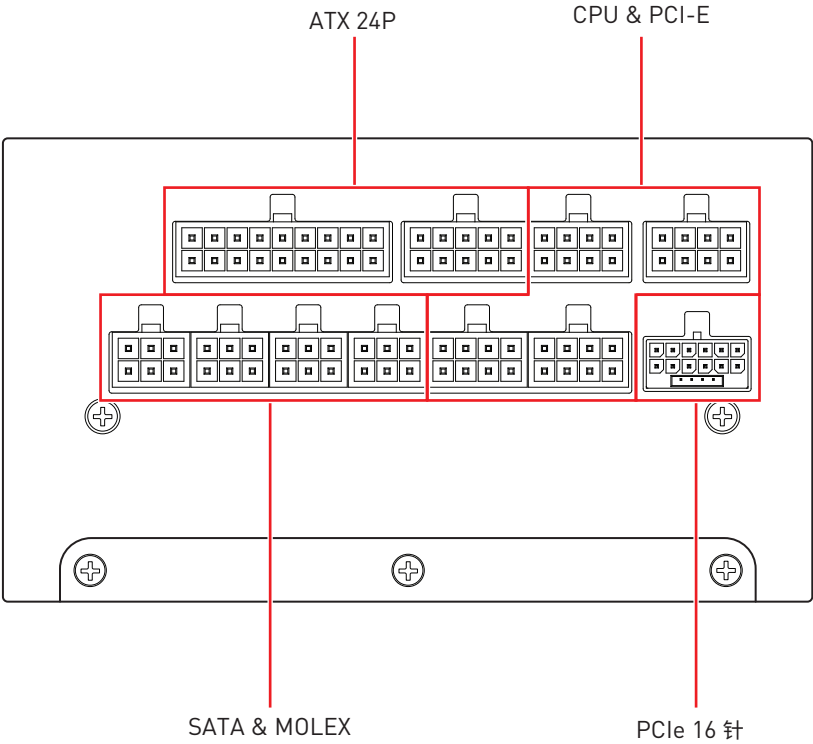

接口和电缆的长度

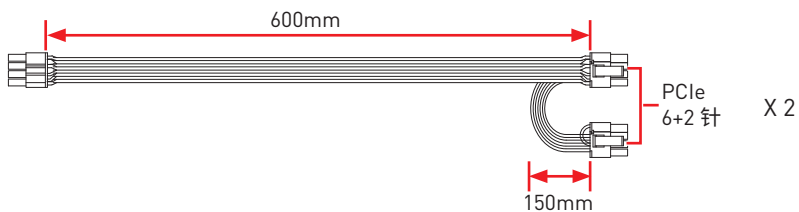
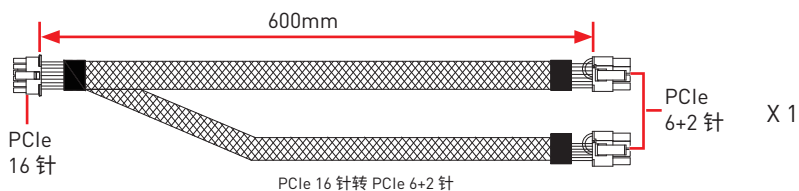
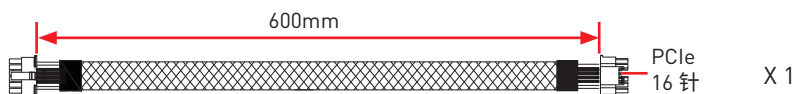
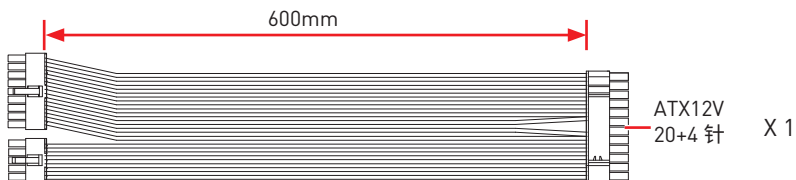

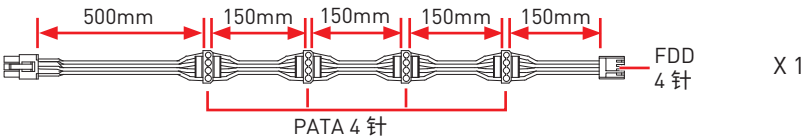
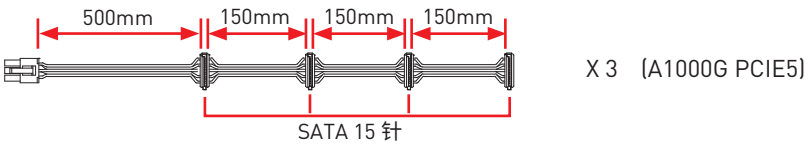
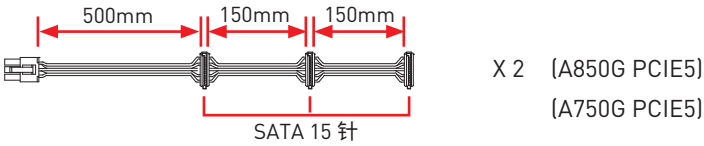
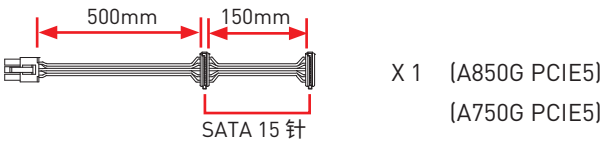

PCIe 16 针电缆安装



使用前请确认将电缆完全插入。

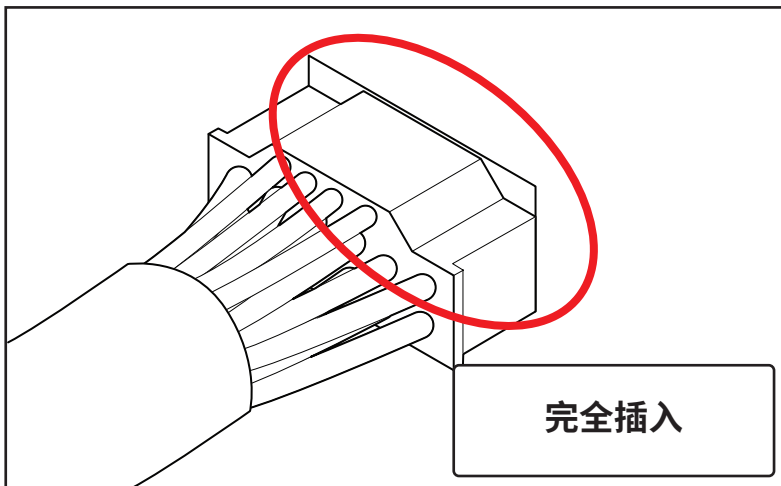
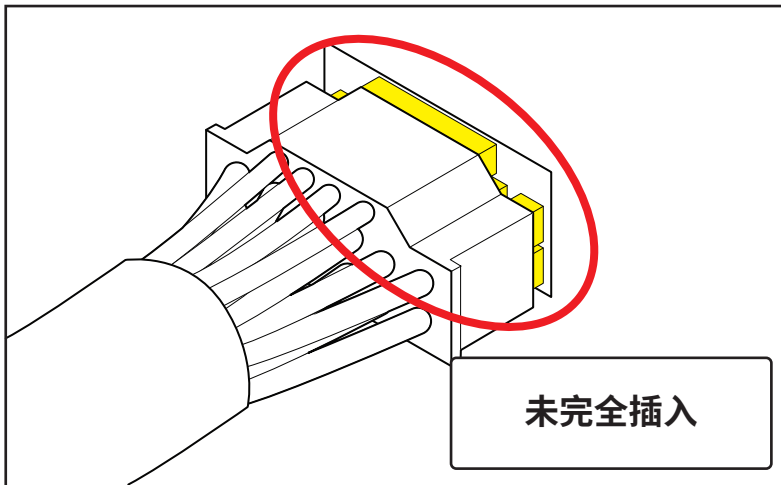

Zero Fan 按钮

按下 Zero Fan 按钮可打开或关闭 Zero RPM Fan 模式。

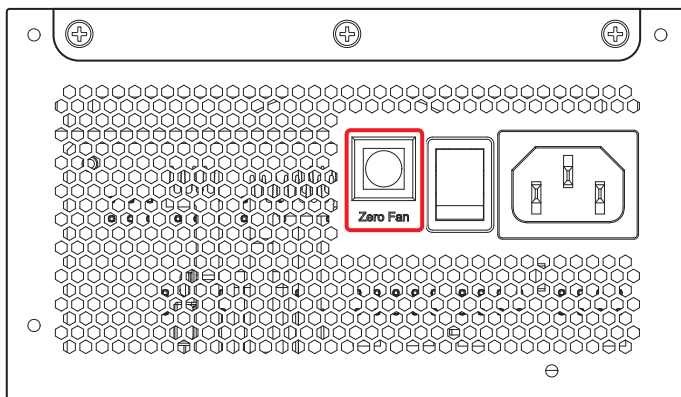

Zero Fan 按钮	Zero RPM Fan 模式	描述
 未按下	打开 (默认)	当系统负载降至指定级别以下时, 电源风扇将停止。
 按下	关闭	电源风扇持续运行。

注意

在默认情况下 Zero RPM Fan 模式处于活动状态;可按按钮停用它。

Contenuti

Specifiche	2
Dimensioni	3
Numero di connettori di alimentazione	4
Connettori rimovibili	5
Connettività e lunghezza dei cavi	6
Installazione del cavo PCIe a 16 pin	8
Tasto Ventola zero	9

Specifiche

1000 W					
Tensione	+5 V	+3,3 V	+12 V	-12 V	+5 Vsb
Carico max.	22,0 A	22,0 A	83,5 A	0,3 A	3,0 A
Carico min.	0,0 A	0,0 A	0,0 A	0,0 A	0,0 A
Potenza combinata (+5 V e +3,3 V)	120 W		1000 W	3,6 W	15,0 W
Potenza totale	1000 W				
Regolazione	± 5%	± 5%	± 5%	± 5%	± 5%
Ondulazione e rumore	30mVp-p	30mVp-p	50mVp-p	40mVp-p	40mVp-p

850 W					
Tensione	+5 V	+3,3 V	+12 V	-12 V	+5 Vsb
Carico max.	22,0 A	22,0 A	70,8 A	0,3 A	3,0 A
Carico min.	0,0 A	0,0 A	0,0 A	0,0 A	0,0 A
Potenza combinata (+5 V e +3,3 V)	120 W		850 W	3,6 W	15,0 W
Potenza totale	850 W				
Regolazione	± 5%	± 5%	± 5%	± 5%	± 5%
Ondulazione e rumore	30mVp-p	30mVp-p	50mVp-p	40mVp-p	40mVp-p

750 W					
Tensione	+5 V	+3,3 V	+12 V	-12 V	+5 Vsb
Carico max.	22,0 A	22,0 A	62,5 A	0,3 A	3,0 A
Carico min.	0,0 A	0,0 A	0,0 A	0,0 A	0,0 A
Potenza combinata (+5 V e +3,3 V)	120 W		750 W	3,6 W	15,0 W
Potenza totale	750 W				
Regolazione	± 5%	± 5%	± 5%	± 5%	± 5%
Ondulazione e rumore	30mVp-p	30mVp-p	50mVp-p	40mVp-p	40mVp-p

Dimensioni

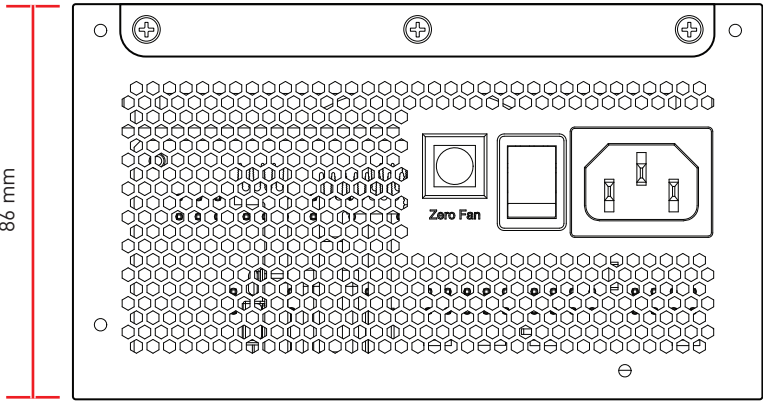
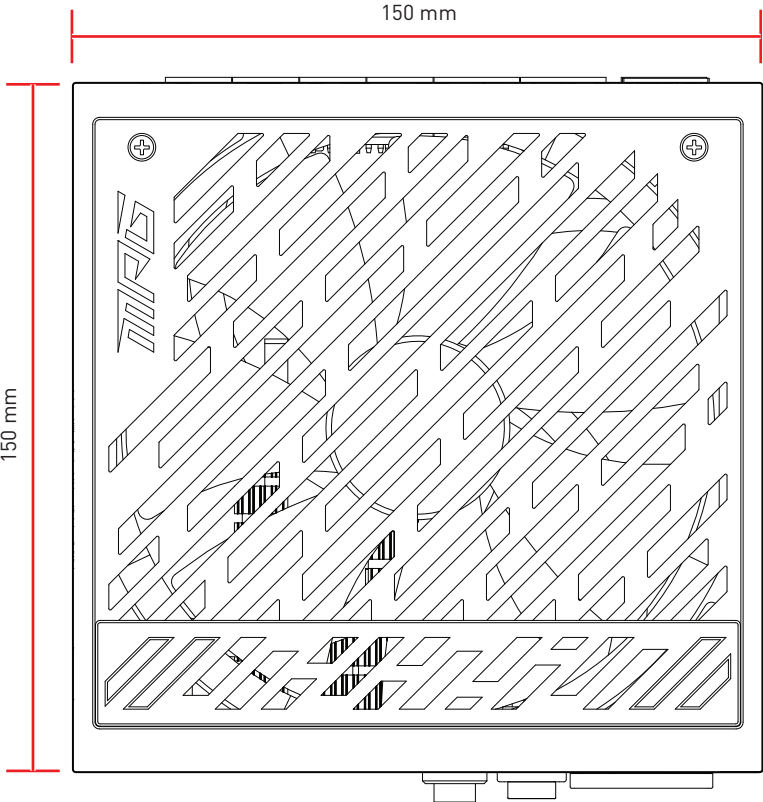

Numero di connettori di alimentazione

Connettori di alimentazione	A1000G PCIE5	A850G PCIE5	A750G PCIE5
ATX12V (scheda madre) 20+4 pin	1	1	1
PCIe 16 pin	1	1	1
EPS12V (CPU) 4+4 pin	2	2	2
PCIe (VGA) 6+2 pin	6	6	6
SATA 15 pin	12	8	8
Periferica (PATA) 4 pin	4	4	4
FDD 4 pin	1	1	1

Connettori rimovibili

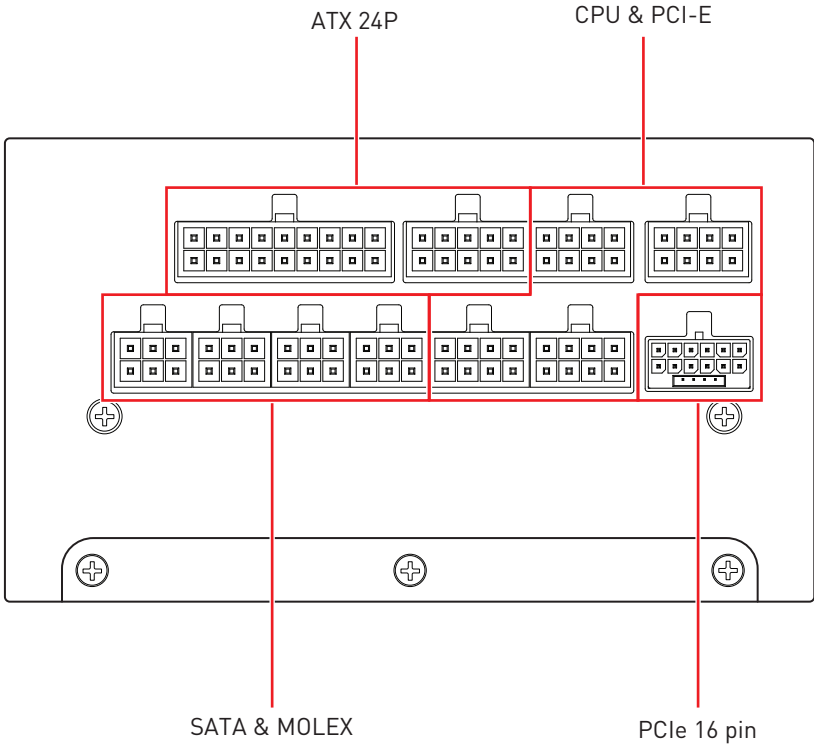

Connettività e lunghezza dei cavi

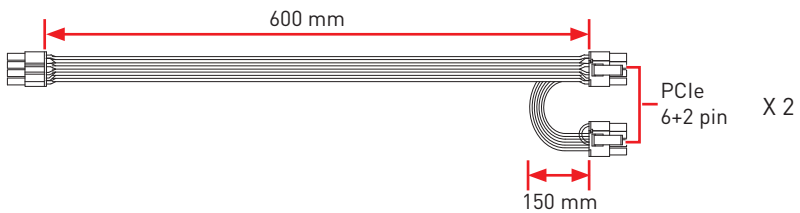
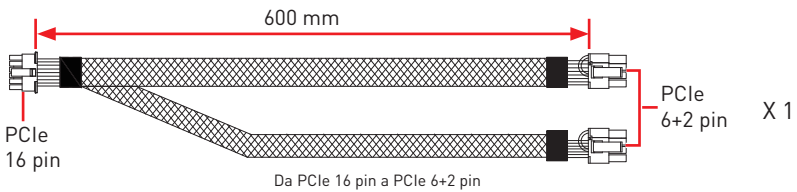
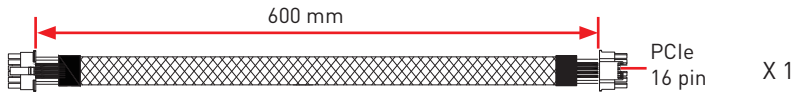
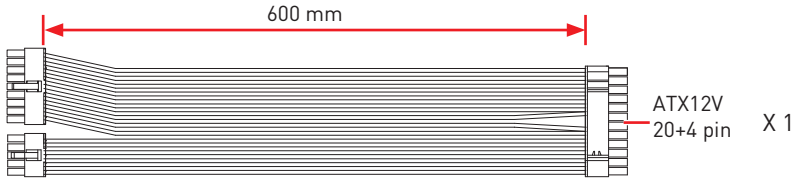

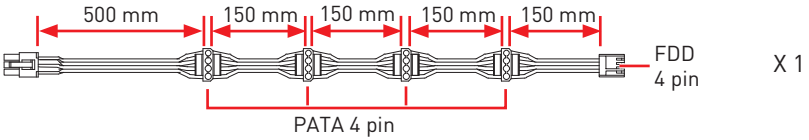
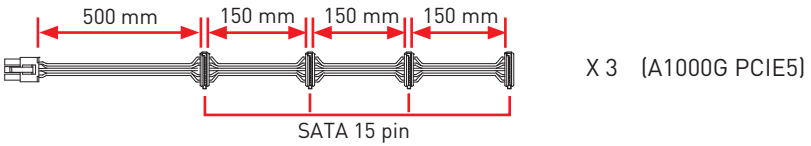
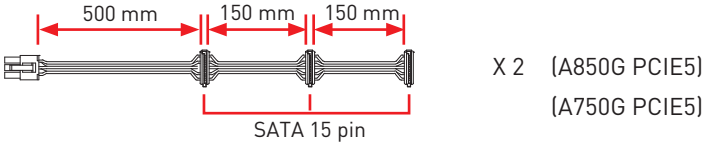
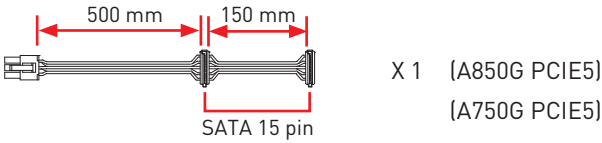
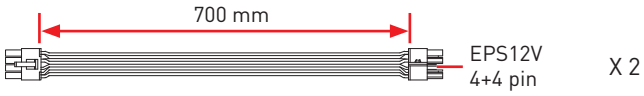

Installazione del cavo PCIe a 16 pin

 **ATTENZIONE**

Inserire completamente il cavo prima dell'uso.

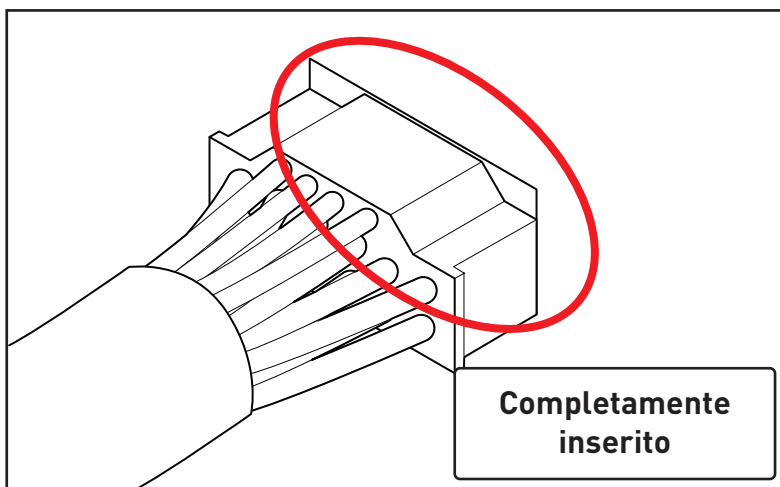
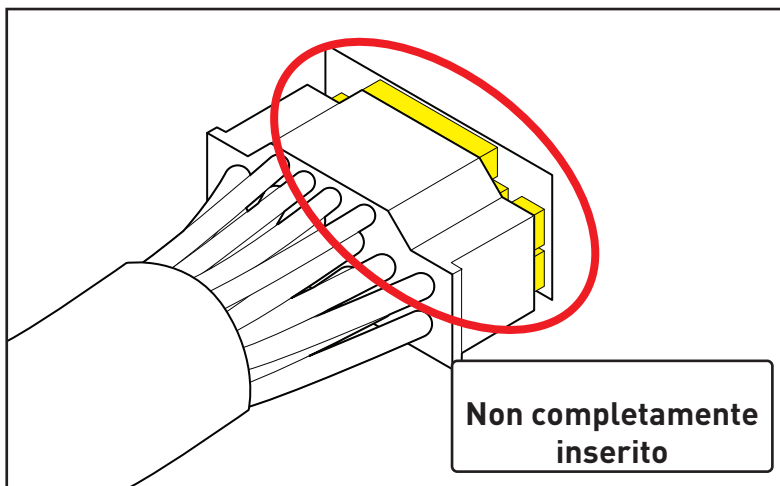

Tasto Ventola zero

Premere il tasto Ventola zero per portare **Modalità Ventola zero giri/min.** su ON o OFF.

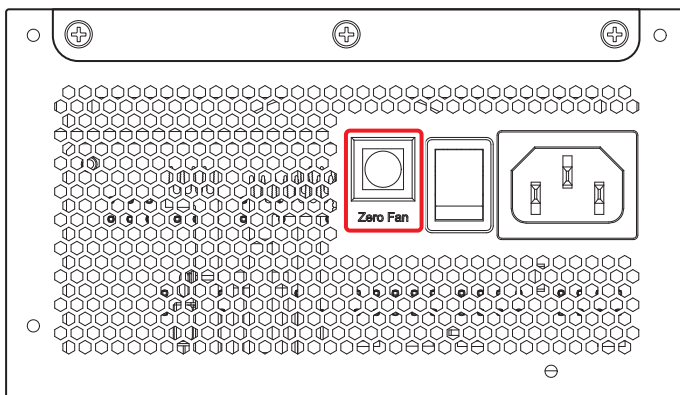

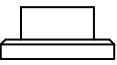
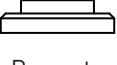
Tasto Ventola zero	Modalità Ventola zero giri/min.	Panoramica
 Non premuto	ON (Impostazione predefinita)	La ventola della PSU si arresta quando il carico del sistema scende al di sotto del livello indicato.
 Premuto	OFF	La ventola della PSU funziona costantemente.

Importante

Modalità Ventola zero giri/min. è attivo per impostazione predefinita; premere il tasto per disattivarlo.

Spis treści

Dane techniczne	2
Wymiary.....	3
Liczba złączy zasilania	4
Odtączone złącza	5
Połączenia i długość kabli	6
Podłączanie 16-pinowego kabla PCIe	8
Przycisk Zero Fan.....	9

Dane techniczne

1000 W					
Napięcie	+5 V	+3,3 V	+12 V	-12 V	+5 Vsb
Maks. obciążenie	22,0 A	22,0 A	83,5 A	0,3 A	3,0 A
Min. obciążenie	0,0 A	0,0 A	0,0 A	0,0 A	0,0 A
Łączna moc (+5 V i +3,3 V)	120 W		1000 W	3,6 W	15,0 W
Całkowita moc	1000 W				
Regulacja	± 5%	± 5%	± 5%	± 5%	± 5%
Tętnienia i szумы	30mVp-p	30mVp-p	50mVp-p	40mVp-p	40mVp-p

850 W					
Napięcie	+5 V	+3,3 V	+12 V	-12 V	+5 Vsb
Maks. obciążenie	22,0 A	22,0 A	70,8 A	0,3 A	3,0 A
Min. obciążenie	0,0 A	0,0 A	0,0 A	0,0 A	0,0 A
Łączna moc (+5 V i +3,3 V)	120 W		850 W	3,6 W	15,0 W
Całkowita moc	850 W				
Regulacja	± 5%	± 5%	± 5%	± 5%	± 5%
Tętnienia i szумы	30mVp-p	30mVp-p	50mVp-p	40mVp-p	40mVp-p

750 W					
Napięcie	+5 V	+3,3 V	+12 V	-12 V	+5 Vsb
Maks. obciążenie	22,0 A	22,0 A	62,5 A	0,3 A	3,0 A
Min. obciążenie	0,0 A	0,0 A	0,0 A	0,0 A	0,0 A
Łączna moc (+5 V i +3,3 V)	120 W		750 W	3,6 W	15,0 W
Całkowita moc	750 W				
Regulacja	± 5%	± 5%	± 5%	± 5%	± 5%
Tętnienia i szумы	30mVp-p	30mVp-p	50mVp-p	40mVp-p	40mVp-p

Wymiary

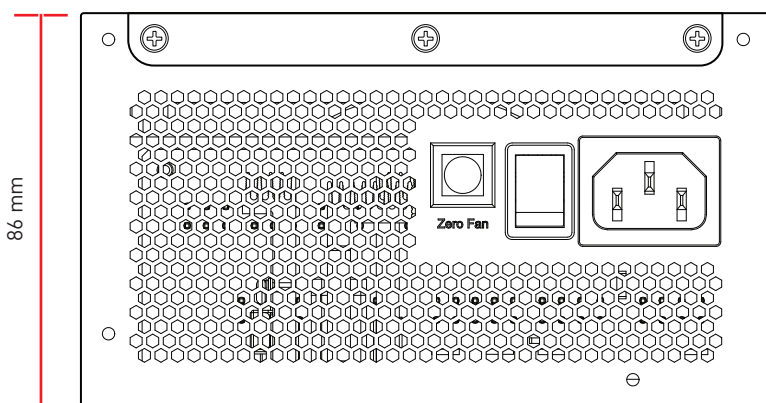
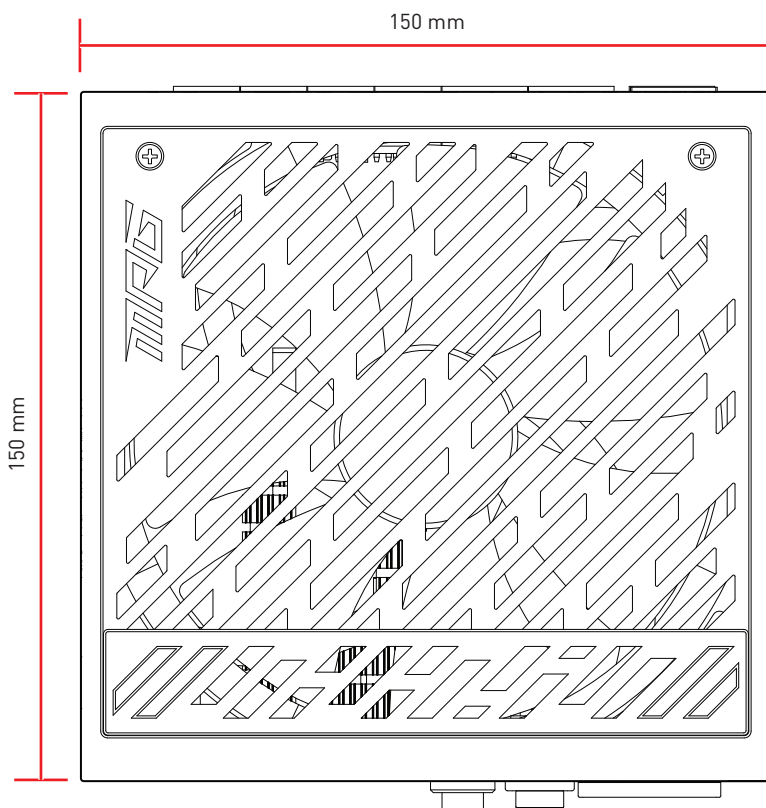

Liczba złączy zasilania

Złącza zasilania	A1000G PCIE5	A850G PCIE5	A750G PCIE5
ATX12V (płyta główna) 20+4 piny	1	1	1
PCIe 16 pinów	1	1	1
EPS12V (procesor) 4+4 piny	2	2	2
PCIe (VGA) 6+2 piny	6	6	6
SATA 15 pinów	12	8	8
Peryferyjne (PATA) 4 piny	4	4	4
FDD 4 piny	1	1	1

Odtaczane złącza

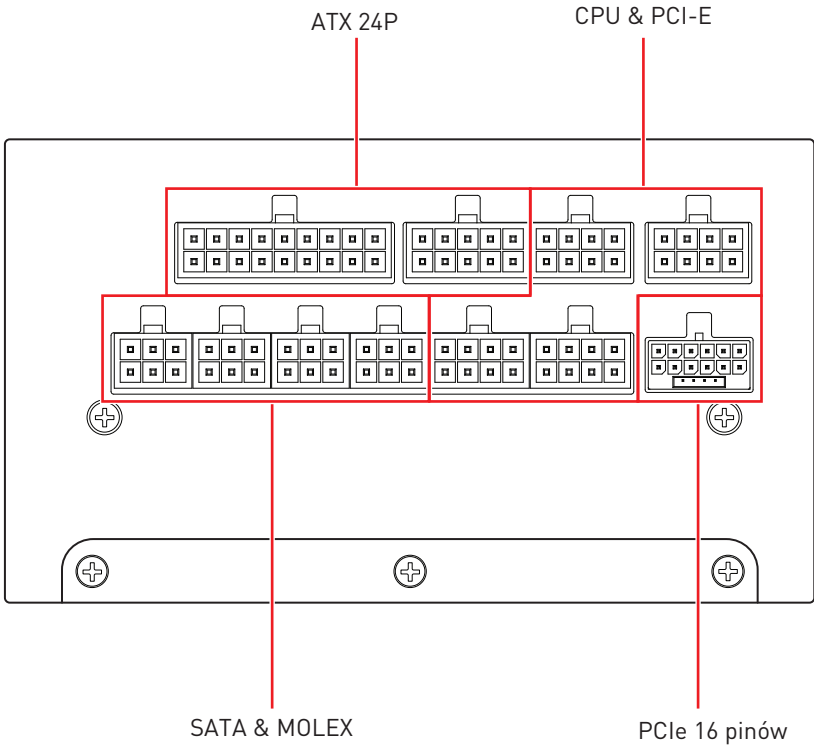

Połączenia i długość kabli

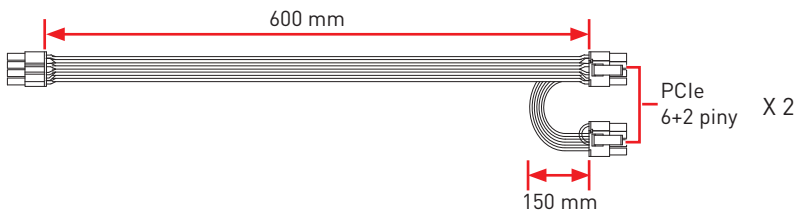
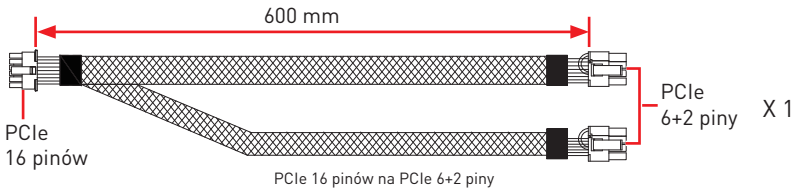
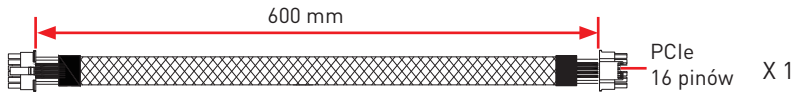
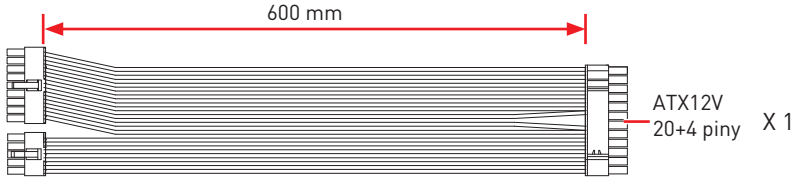

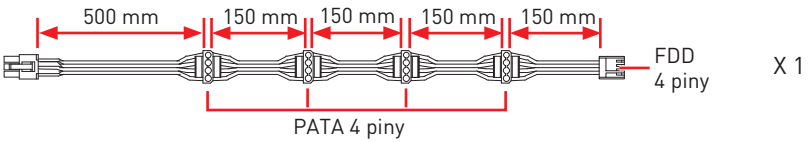
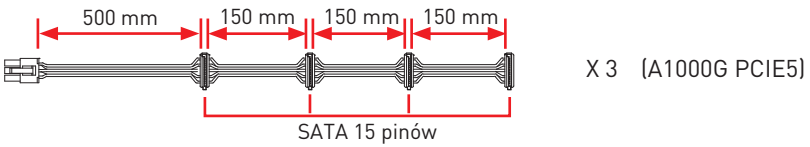
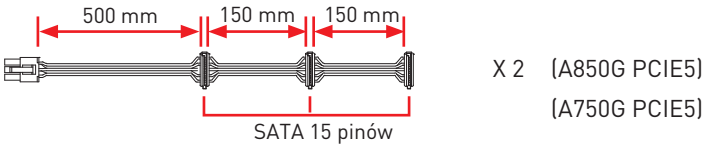
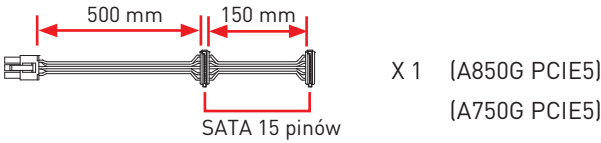
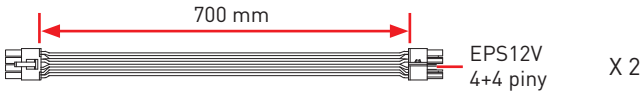

Podłączanie 16-pinowego kabla PCIe

 **PRZESTROGA**

Kabel należy włożyć do końca gniazda.

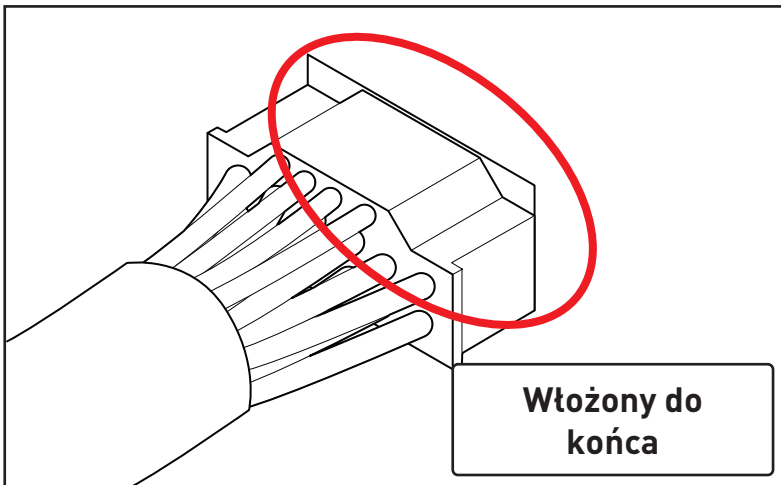
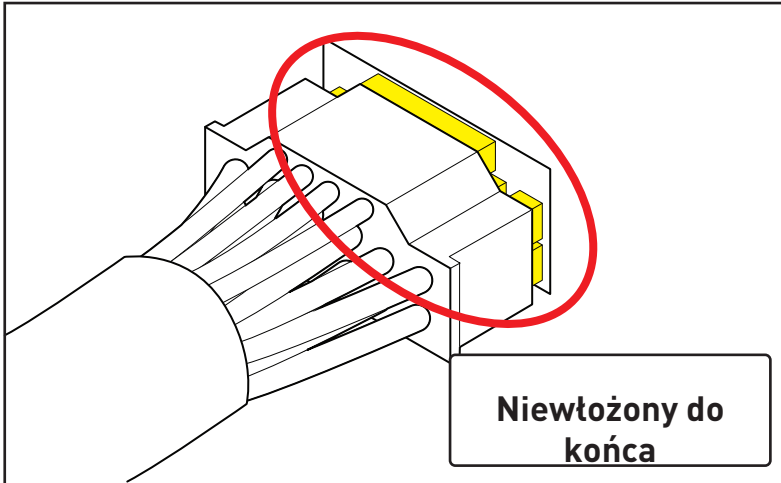

Przycisk Zero Fan

Naciśnij przycisk Zero Fan, aby włączyć lub wyłączyć pozycję **Tryb zerowych obrotów wentylatora**.

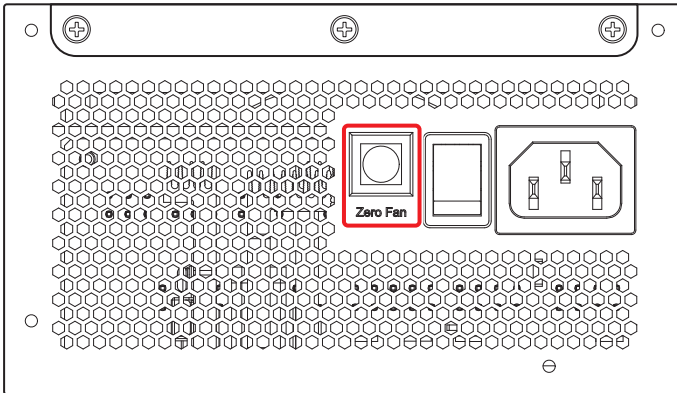

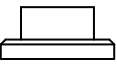
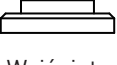
Przycisk Zero Fan	Tryb zerowych obrotów wentylatora	Opis
 Niewciśnięty	WŁ. (domyślnie)	Wentylator zasilacza wyłączy się, gdy obciążenie systemu spadnie poniżej określonego poziomu.
 Wciśnięty	WYŁ.	Wentylator zasilacza działa w sposób ciągły.

Ważne

Tryb zerowych obrotów wentylatora jest domyślnie włączony. Aby go wyłączyć, należy wcisnąć przycisk.

Índice

Especificações	2
Dimensões	3
Número de conectores de alimentação	4
Conectores amovíveis	5
Conectividade e comprimentos dos cabos.....	6
Instalação do cabo PCIe de 16 pinos.....	8
Botão Zero Fan	9

Especificações

1000W					
Tensão	+5V	+3,3V	+12V	-12V	+5Vsb
Carga máx.	22,0A	22,0A	83,5A	0,3A	3,0A
Carga mín.	0,0A	0,0A	0,0A	0,0A	0,0A
Potência combinada (+5 V e +3,3 V)	120W		1000W	3,6W	15,0W
Potência total	1000W				
Regulação	± 5%	± 5%	± 5%	± 5%	± 5%
Ruído e ondulação	30mVp-p	30mVp-p	50mVp-p	40mVp-p	40mVp-p

850W					
Tensão	+5V	+3,3V	+12V	-12V	+5Vsb
Carga máx.	22,0A	22,0A	70,8A	0,3A	3,0A
Carga mín.	0,0A	0,0A	0,0A	0,0A	0,0A
Potência combinada (+5 V e +3,3 V)	120W		850W	3,6W	15,0W
Potência total	850W				
Regulação	± 5%	± 5%	± 5%	± 5%	± 5%
Ruído e ondulação	30mVp-p	30mVp-p	50mVp-p	40mVp-p	40mVp-p

750W					
Tensão	+5V	+3,3V	+12V	-12V	+5Vsb
Carga máx.	22,0A	22,0A	62,5A	0,3A	3,0A
Carga mín.	0,0A	0,0A	0,0A	0,0A	0,0A
Potência combinada (+5 V e +3,3 V)	120W		750W	3,6W	15,0W
Potência total	750W				
Regulação	± 5%	± 5%	± 5%	± 5%	± 5%
Ruído e ondulação	30mVp-p	30mVp-p	50mVp-p	40mVp-p	40mVp-p

Dimensões

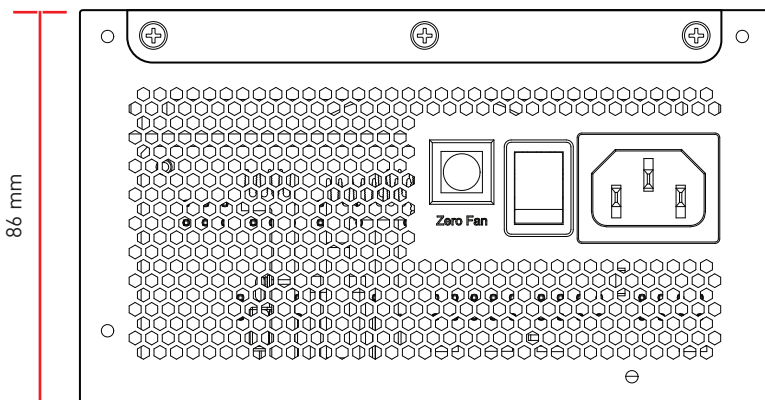
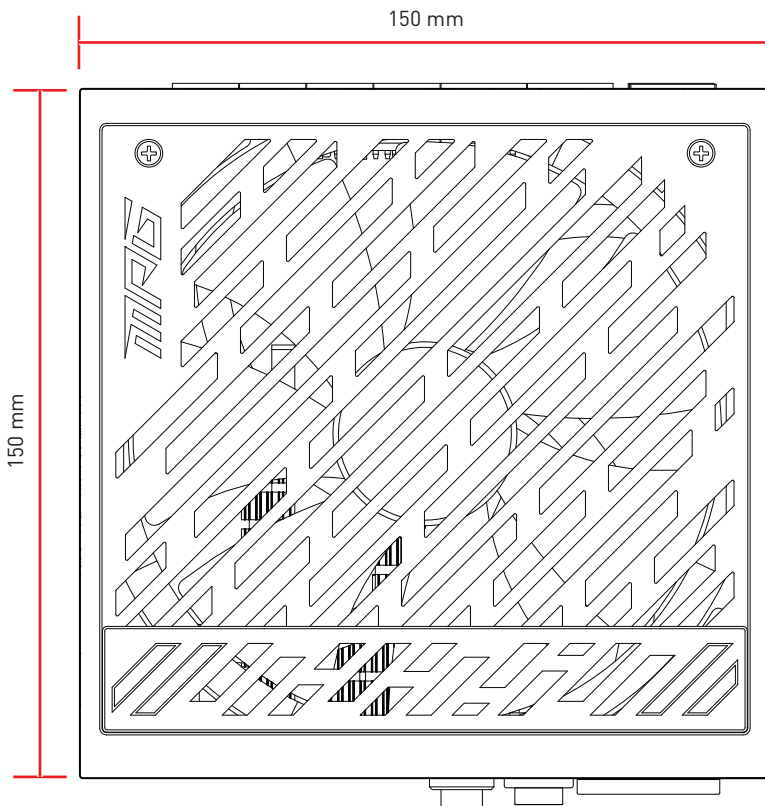

Número de conectores de alimentação

Conectores de alimentação	A1000G PCIE5	A850G PCIE5	A750G PCIE5
ATX12V (placa principal) 20+4 pinos	1	1	1
PCIe 16 pinos	1	1	1
EPS12V (CPU) 4+4 pinos	2	2	2
PCIe (VGA) 6+2 pinos	6	6	6
SATA 15 pinos	12	8	8
Periférico (PATA) 4 pinos	4	4	4
FDD 4 pinos	1	1	1

Conectores amovíveis

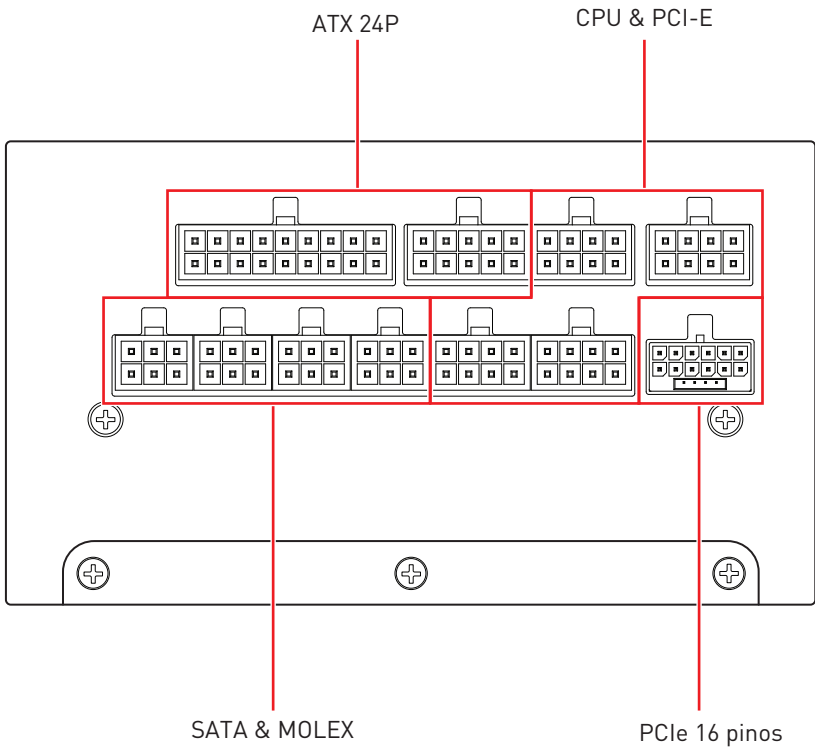

Conectividade e comprimentos dos cabos

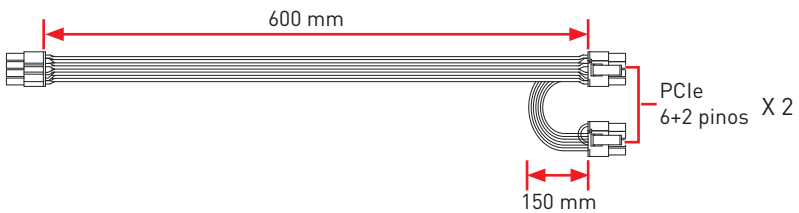
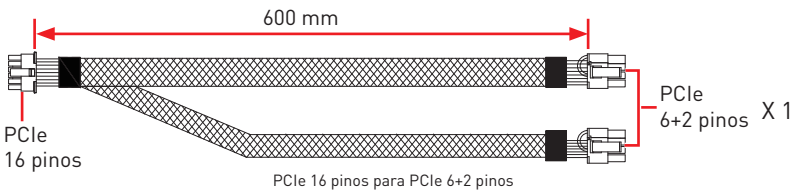
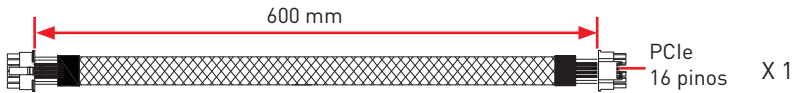
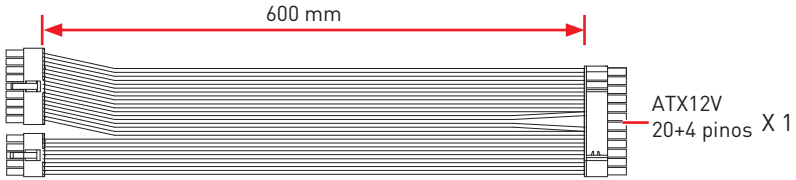

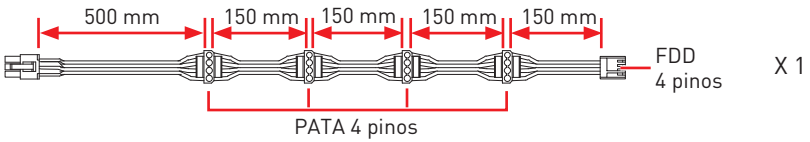
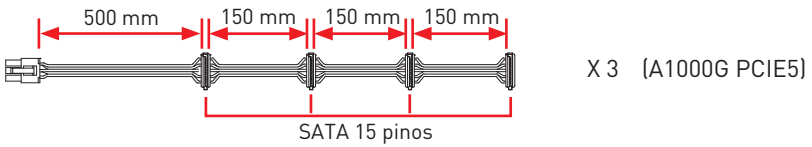
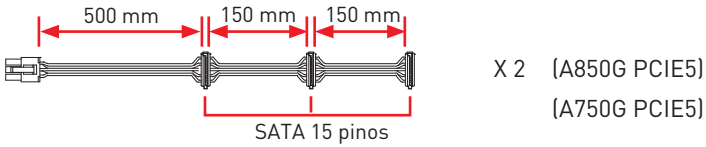
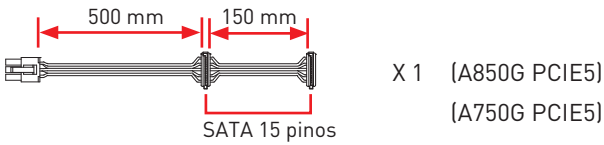
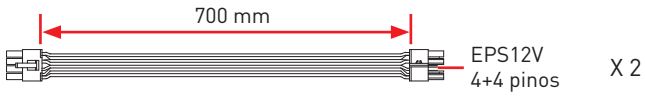

Instalação do cabo PCIe de 16 pinos

 **ATENÇÃO**

Introduza o cabo totalmente antes de utilizar.

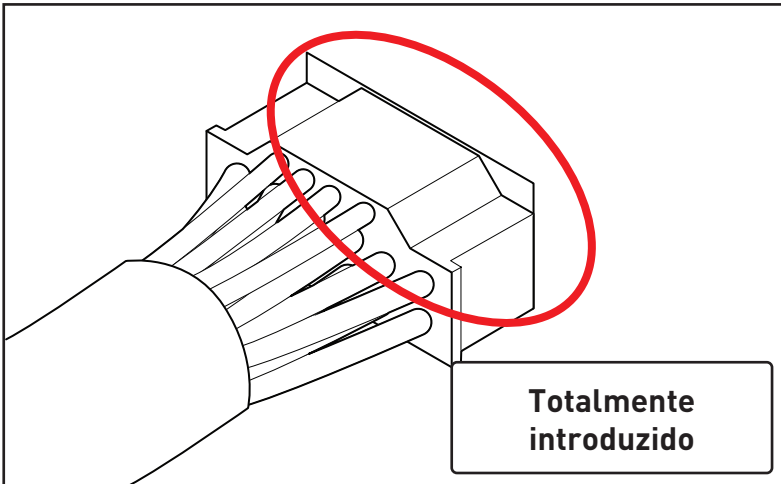
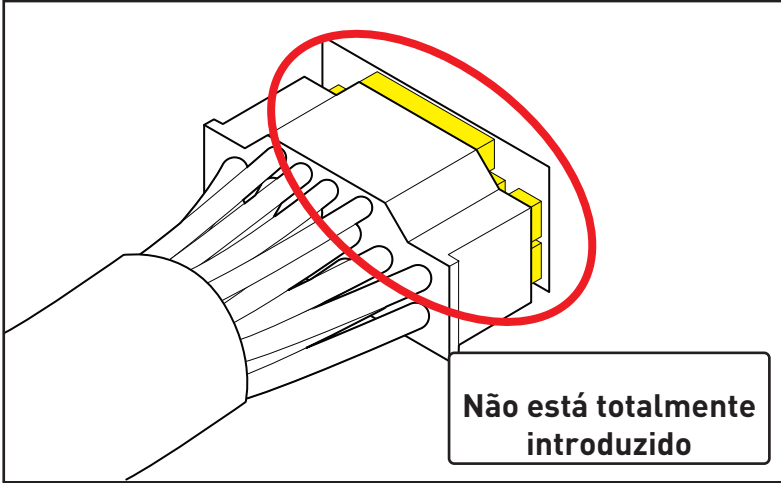

Botão Zero Fan

Pressione o botão Zero para ligar ou desligar o **modo de ventilador de zero RPM**.

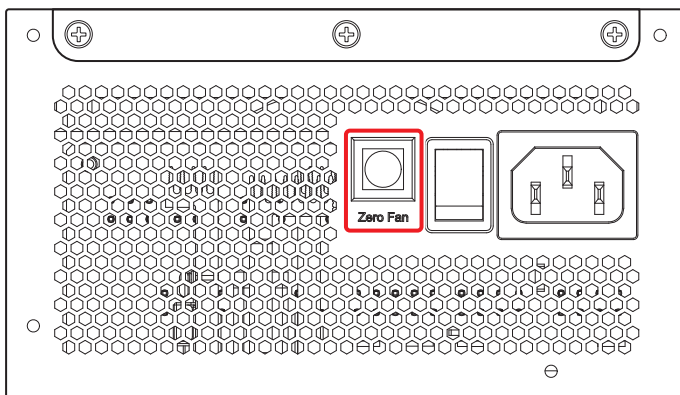

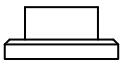
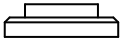
Botão Zero Fan	Modo de ventilador de zero RPM	Descrição
 Não pressionado	ATIVADO (Predefinição)	O ventilador da fonte de alimentação parar quando a carga do sistema desce abaixo do nível designado.
 Pressionado	DESATIVADO	O ventilador da fonte de alimentação funciona constantemente.

Importante

O modo de ventilador de zero RPM está ativado por predefinição; pressione o botão para o desativar.

Contenido

Especificaciones	2
Dimensiones	3
Número de conectores de alimentación	4
Conectores desmontables.....	5
Conectividad y longitud de los cables	6
Instalación del cable PCIe de 16 contactos	8
Botón Cero ventilador	9

Especificaciones

1000 W					
Tensión	+5 V	+3,3 V	+12 V	-12 V	+5 Vsb
Carga máxima	22,0 A	22,0 A	83,5 A	0,3 A	3,0 A
Carga mínima	0,0 A	0,0 A	0,0 A	0,0 A	0,0 A
Potencia combinada (+5 V y +3,3 V)	120 W		1000 W	3,6 W	15,0 W
Potencia total	1000 W				
Regulación	± 5 %	± 5 %	± 5 %	± 5 %	± 5 %
Pulso y ruido	30 mVp-p	30 mVp-p	50 mVp-p	40 mVp-p	40 mVp-p

850 W					
Tensión	+5 V	+3,3 V	+12 V	-12 V	+5 Vsb
Carga máxima	22,0 A	22,0 A	70,8 A	0,3 A	3,0 A
Carga mínima	0,0 A	0,0 A	0,0 A	0,0 A	0,0 A
Potencia combinada (+5 V y +3,3 V)	120 W		850 W	3,6 W	15,0 W
Potencia total	850 W				
Regulación	± 5 %	± 5 %	± 5 %	± 5 %	± 5 %
Pulso y ruido	30 mVp-p	30 mVp-p	50 mVp-p	40 mVp-p	40 mVp-p

750 W					
Tensión	+5 V	+3,3 V	+12 V	-12 V	+5 Vsb
Carga máxima	22,0 A	22,0 A	62,5 A	0,3 A	3,0 A
Carga mínima	0,0 A	0,0 A	0,0 A	0,0 A	0,0 A
Potencia combinada (+5 V y +3,3 V)	120 W		750 W	3,6 W	15,0 W
Potencia total	750 W				
Regulación	± 5 %	± 5 %	± 5 %	± 5 %	± 5 %
Pulso y ruido	30 mVp-p	30 mVp-p	50 mVp-p	40 mVp-p	40 mVp-p

Dimensiones

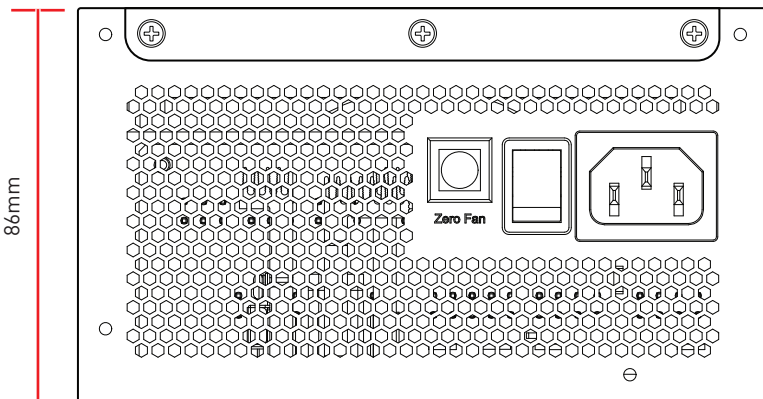
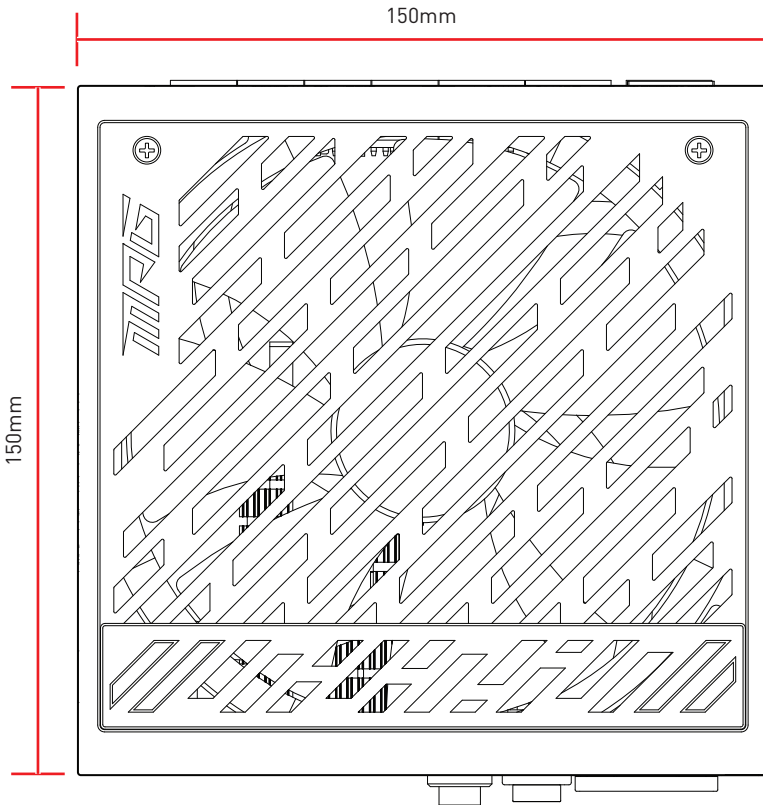

Número de conectores de alimentación

Conectores de alimentación	A1000G PCIE5	A850G PCIE5	A750G PCIE5
ATX12V (placa base) de 20+4 contactos	1	1	1
PCIe de 16 contactos	1	1	1
EPS12V (CPU) de 4+4 contactos	2	2	2
PCIe (VGA) de 6+2 contactos	6	6	6
SATA de 15 contactos	12	8	8
Periférico (PATA) de 4 contactos	4	4	4
FDD de 4 contactos	1	1	1

Conectores desmontables

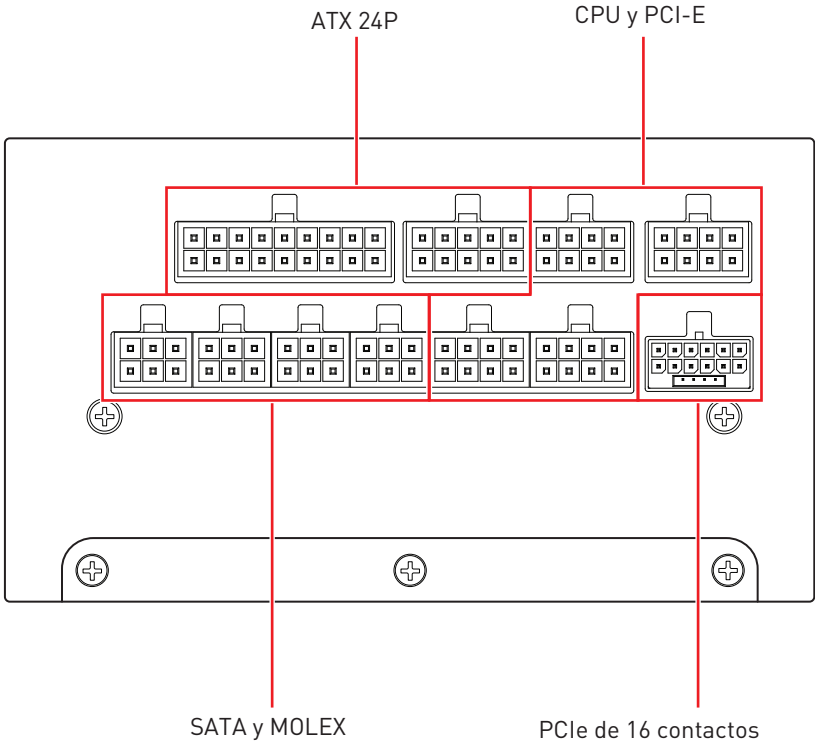

Conectividad y longitud de los cables

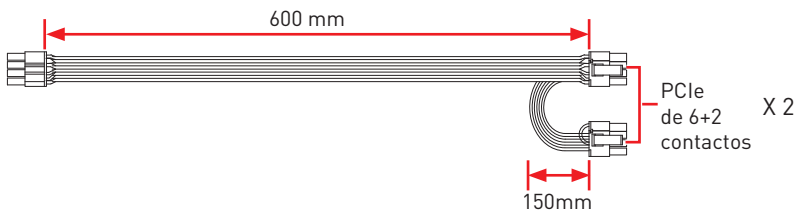
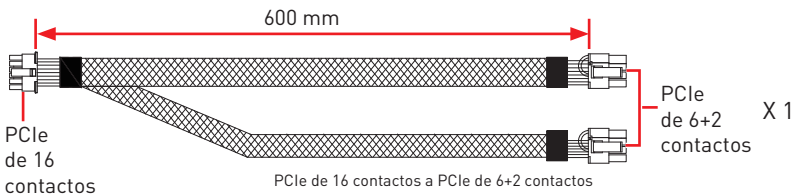
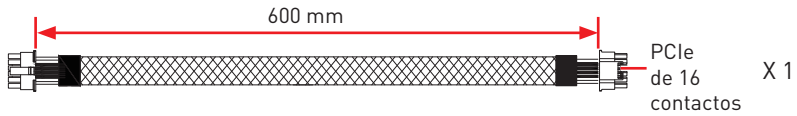
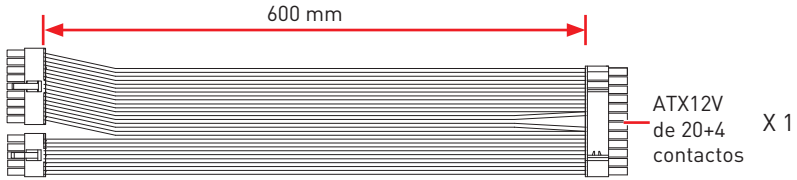

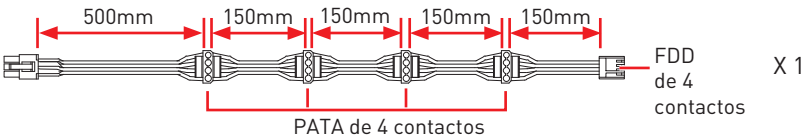
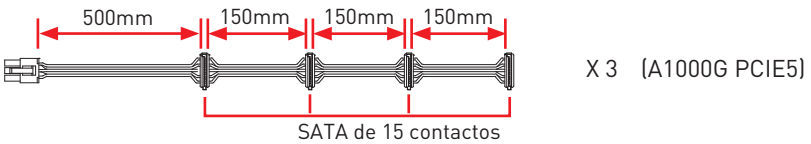
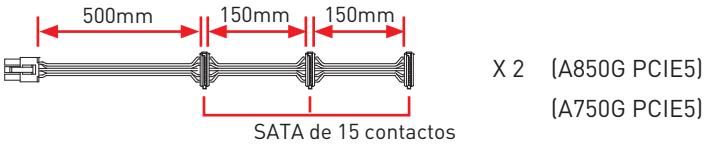
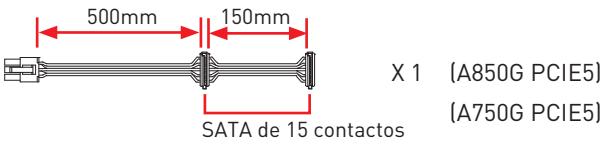
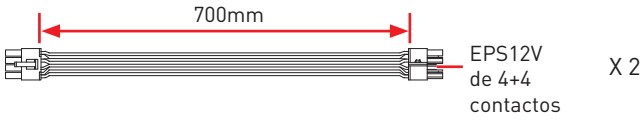

Instalación del cable PCIe de 16 contactos

 **PRECAUCIÓN**

Inserte completamente el cable antes de utilizarlo.

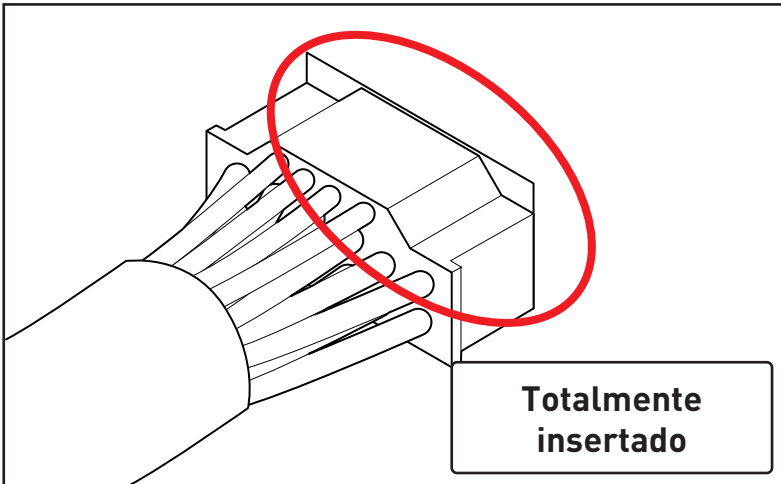
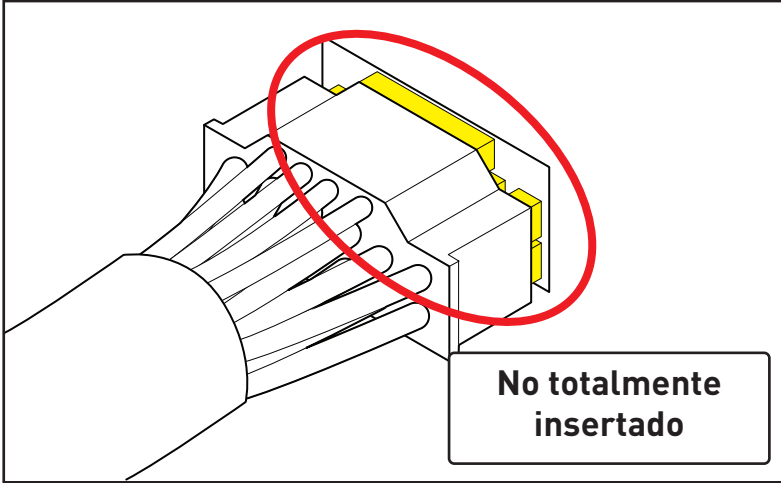

Botón Cero ventilador

Presione el botón Cero ventilador para **ACTIVAR** o **DESACTIVAR** el **Modo de ventilador con cero r.p.m.**

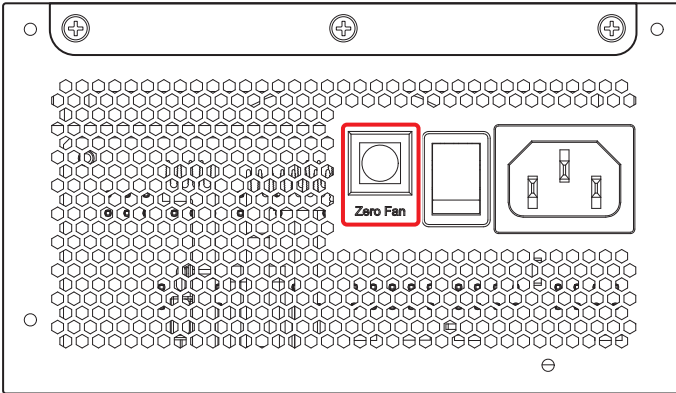

Botón Cero ventilador	Modo de ventilador con cero r.p.m.	Descripción
 Sin presionar	ACTIVADO (opción predeterminada)	El ventilador de la fuente de alimentación se detiene cuando la carga del sistema cae por debajo del nivel designado.
 Presionado	DESACTIVADO	El ventilador de la fuente de alimentación funciona constantemente.

Importante

El modo de ventilador con cero r.p.m. está activo de forma predeterminada; presione el botón para desactivarlo.

İçindekiler

Teknik Özellikler.....	2
Boyutlar	3
Güç Konektörü Sayısı	4
Ayrılabilir Konektörler	5
Bağlantı ve Kablo Uzunlukları.....	6
PCIe 16 Pin Kablo Kurulumu.....	8
Zero Fan Düğmesi.....	9

Teknik Özellikler

1000W					
Voltaj	+5V	+3,3V	+12V	-12V	+5Vsb
Maks. yük	22,0A	22,0A	83,5A	0,3A	3,0A
Min. yük	0,0A	0,0A	0,0A	0,0A	0,0A
Birleşik güç (+5V&+3,3V)	120W		1000W	3,6W	15,0W
Toplam Güç	1000W				
Regülasyon	± %5	± %5	± %5	± %5	± %5
Dalgalanma ve Gürültü	30mVp-p	30mVp-p	50mVp-p	40mVp-p	40mVp-p

850W					
Voltaj	+5V	+3,3V	+12V	-12V	+5Vsb
Maks. yük	22,0A	22,0A	70,8A	0,3A	3,0A
Min. yük	0,0A	0,0A	0,0A	0,0A	0,0A
Birleşik güç (+5V&+3,3V)	120W		850W	3,6W	15,0W
Toplam Güç	850W				
Regülasyon	± %5	± %5	± %5	± %5	± %5
Dalgalanma ve Gürültü	30mVp-p	30mVp-p	50mVp-p	40mVp-p	40mVp-p

750W					
Voltaj	+5V	+3,3V	+12V	-12V	+5Vsb
Maks. yük	22,0A	22,0A	62,5A	0,3A	3,0A
Min. yük	0,0A	0,0A	0,0A	0,0A	0,0A
Birleşik güç (+5V&+3,3V)	120W		750W	3,6W	15,0W
Toplam Güç	750W				
Regülasyon	± %5	± %5	± %5	± %5	± %5
Dalgalanma ve Gürültü	30mVp-p	30mVp-p	50mVp-p	40mVp-p	40mVp-p

Boyutlar

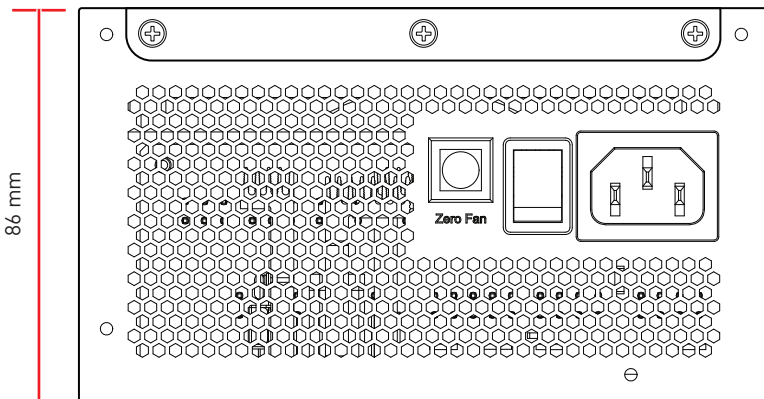
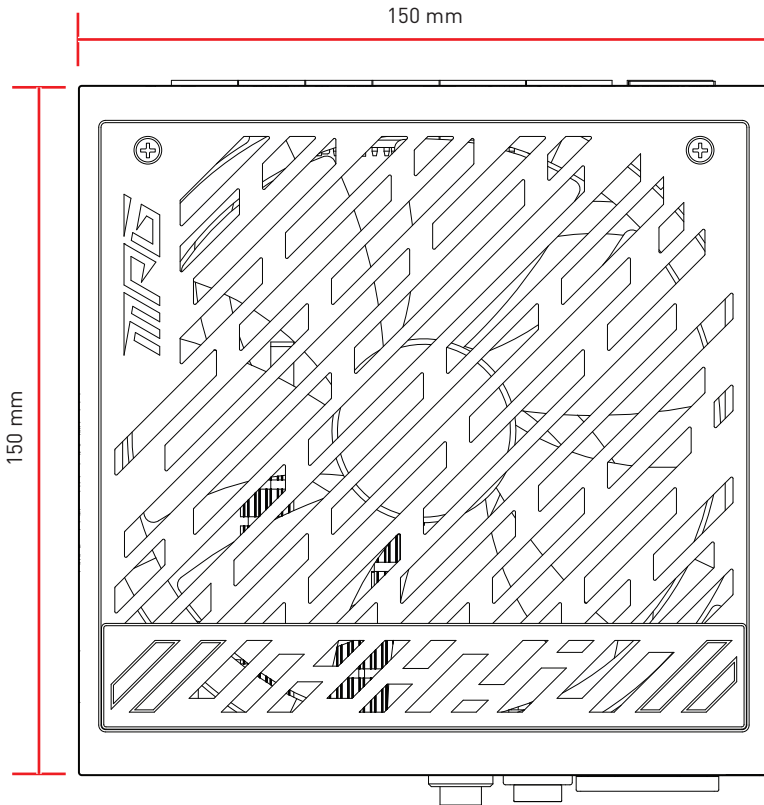

Güç Konektörü Sayısı

Güç Konektörleri	A1000G PCIE5	A850G PCIE5	A750G PCIE5
ATX12V (Anakart) 20+4 pin	1	1	1
PCIe 16 pin	1	1	1
EPS12V (CPU) 4+4 pin	2	2	2
PCIe (VGA) 6+2 pin	6	6	6
SATA 15 pin	12	8	8
Çevresel (PATA) 4 pin	4	4	4
FDD 4 pin	1	1	1

Ayrılabilir Konektörler

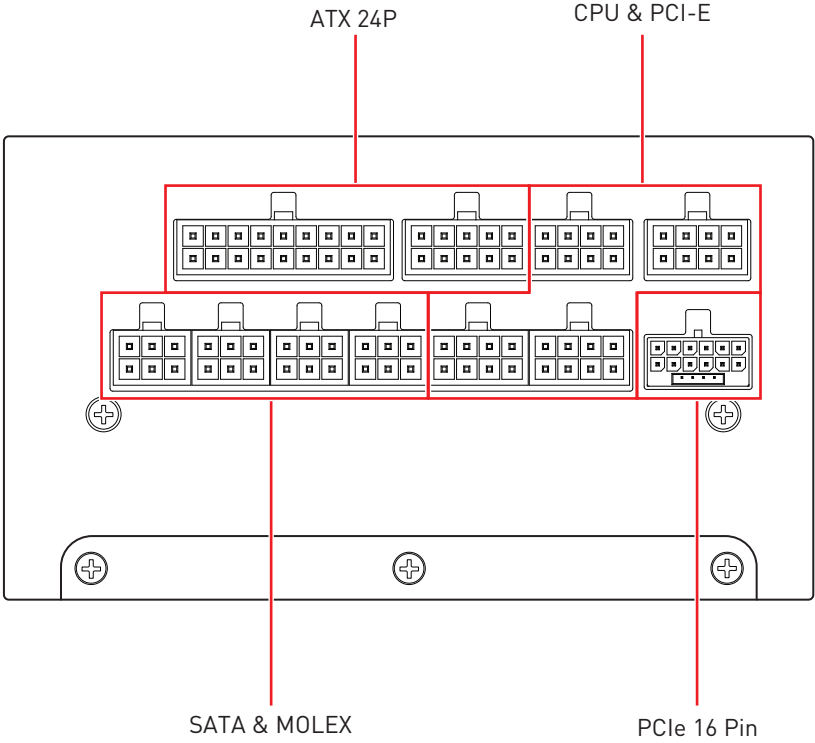

Bağlantı ve Kablo Uzunlukları

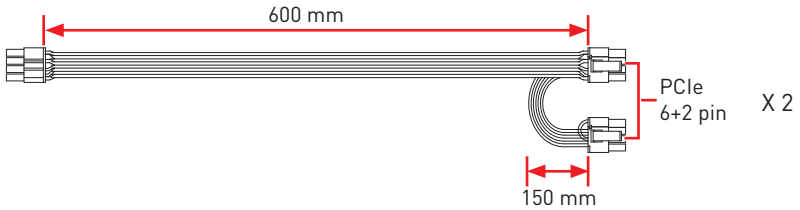
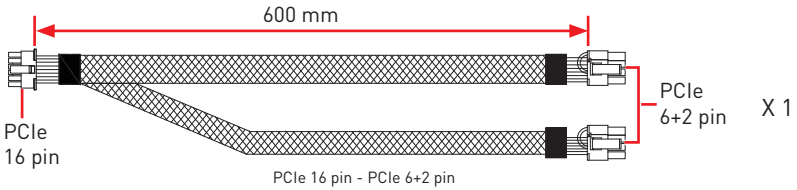
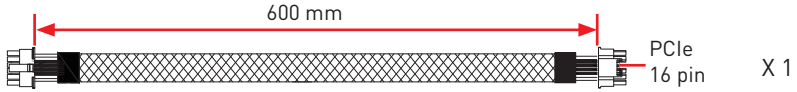
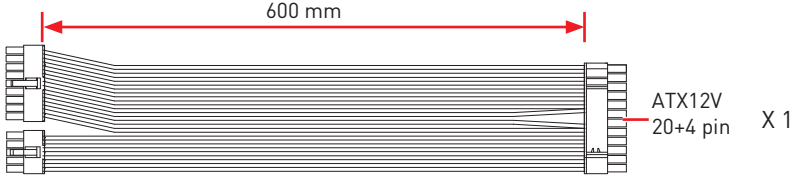

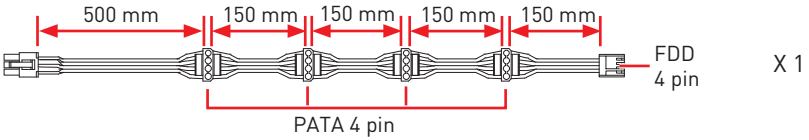
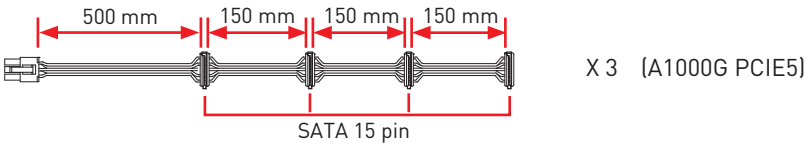
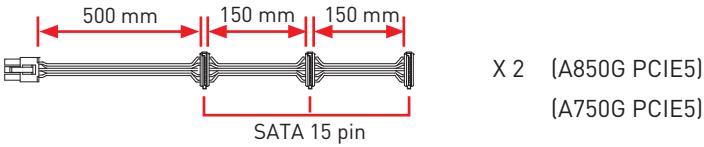
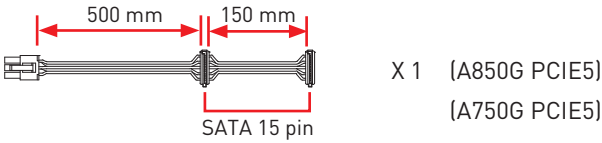
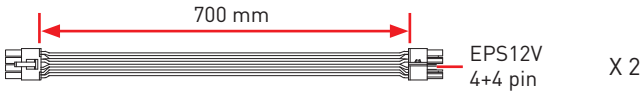

PCIe 16 Pin Kablo Kurulumu

! DİKKAT

Kullanmadan önce kabloyu lütfen sonuna kadar takın.

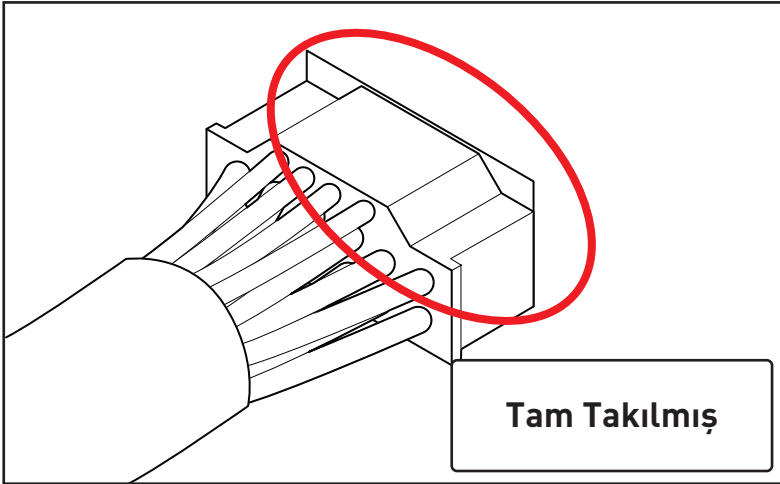
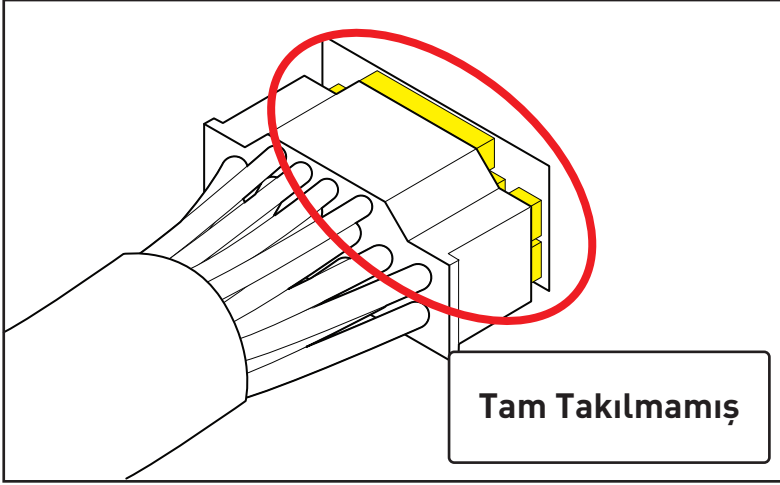

Zero Fan Düğmesi

Zero RPM Fan Modu'nu AÇMAK veya KAPATMAK için Zero Fan düğmesine basın.

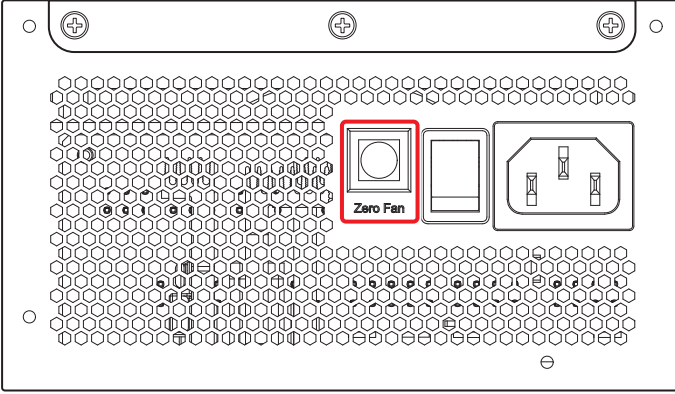

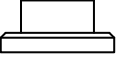
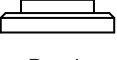
Zero Fan Düğmesi	Zero RPM Fan Modu	Açıklama
 Basılmamış	AÇIK (Varsayılan)	Sistem yükü belirlenen seviyenin altına düştüğünde PSU fanı durur.
 Basılı	KAPALI	PSU fanı sürekli çalışır.

Önemli

Zero RPM Fan Modu varsayılan olarak etkindir; devre dışı bırakmak için düğmeye basın.

Obsah

Technické údaje.....	2
Rozměry	3
Počet napájecích konektorů	4
Odnímatelné konektory.....	5
Možnosti připojení a délka kabelů	6
Instalace 16 kolíkového kabelu PCIe	8
Tlačítko Zero Fan.....	9

Technické údaje

1000 W					
Napětí	+5 V	+3,3 V	+12 V	-12 V	+5Vsb
Maximální zatížení	22,0 A	22,0 A	83,5 A	0,3 A	3,0 A
Min. zatížení	0,0 A	0,0 A	0,0 A	0,0 A	0,0 A
Kombinovaný výkon (+5V&+3,3V)	120 W		1000 W	3,6 W	15,0 W
Celkový výkon	1000 W				
Regulace	± 5%	± 5%	± 5%	± 5%	± 5%
Zvlnění a šum	30 mVp-p	30 mVp-p	50 mVp-p	40 mVp-p	40 mVp-p

850 W					
Napětí	+5 V	+3,3 V	+12 V	-12 V	+5Vsb
Maximální zatížení	22,0 A	22,0 A	70,8 A	0,3 A	3,0 A
Min. zatížení	0,0 A	0,0 A	0,0 A	0,0 A	0,0 A
Kombinovaný výkon (+5V&+3,3V)	120 W		850 W	3,6 W	15,0 W
Celkový výkon	850 W				
Regulace	± 5%	± 5%	± 5%	± 5%	± 5%
Zvlnění a šum	30 mVp-p	30 mVp-p	50 mVp-p	40 mVp-p	40 mVp-p

750 W					
Napětí	+5 V	+3,3 V	+12 V	-12 V	+5Vsb
Maximální zatížení	22,0 A	22,0 A	62,5 A	0,3 A	3,0 A
Min. zatížení	0,0 A	0,0 A	0,0 A	0,0 A	0,0 A
Kombinovaný výkon (+5V&+3,3V)	120 W		750 W	3,6 W	15,0 W
Celkový výkon	750 W				
Regulace	± 5%	± 5%	± 5%	± 5%	± 5%
Zvlnění a šum	30 mVp-p	30 mVp-p	50 mVp-p	40 mVp-p	40 mVp-p

Rozměry

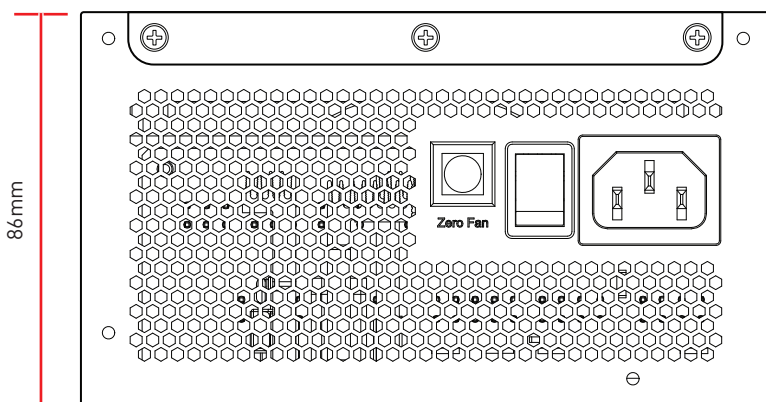
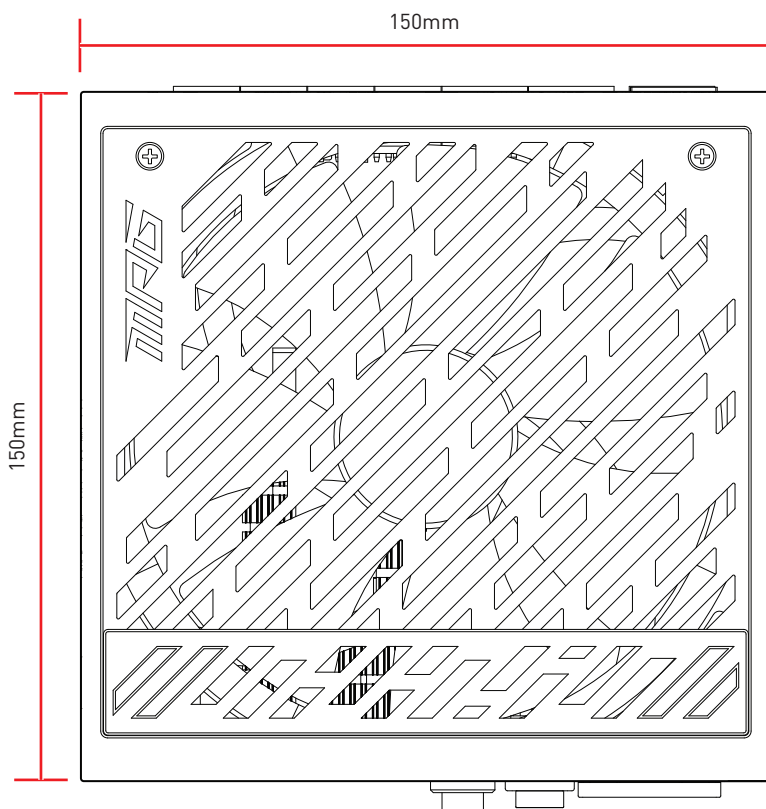

Počet napájecích konektorů

Napájecí konektory	A1000G PCIE5	A850G PCIE5	A750G PCIE5
ATX12V (základní deska) 20+4 kolíky	1	1	1
PCIe 16 kolíků	1	1	1
EPS12V (CPU) 4+4 kolíky	2	2	2
PCIe (VGA) 6+2 kolíky	6	6	6
SATA 15 kolíků	12	8	8
Periferní (PATA) 4 kolíky	4	4	4
FDD 4 kolíky	1	1	1

Odnímatelné konektory

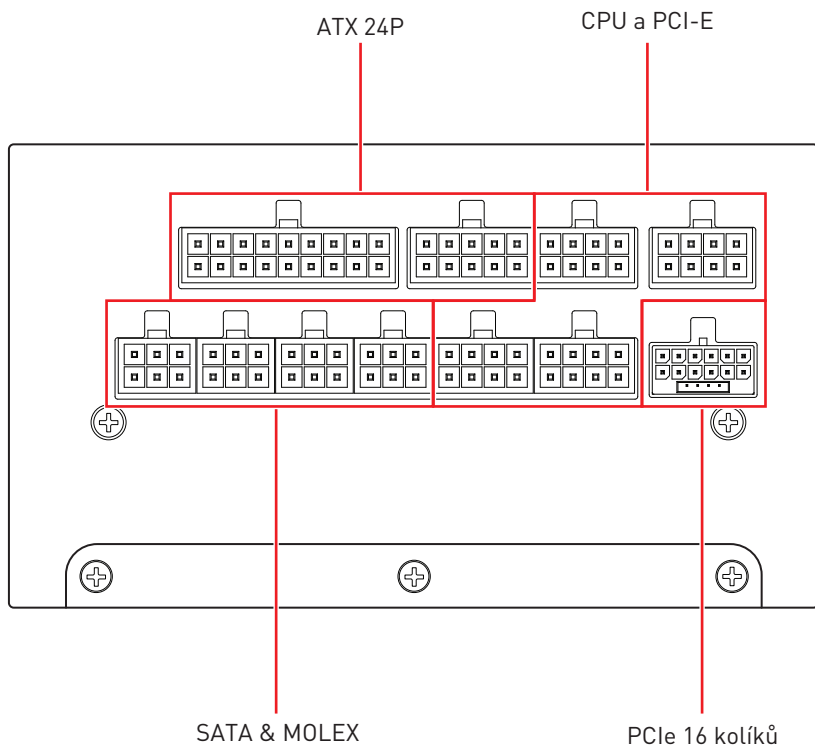

Možnosti připojení a délka kabelů

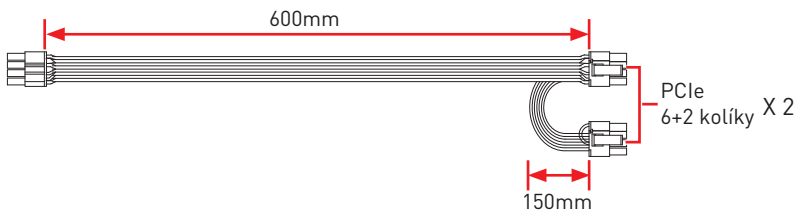
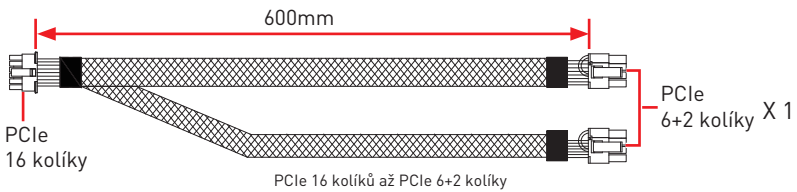
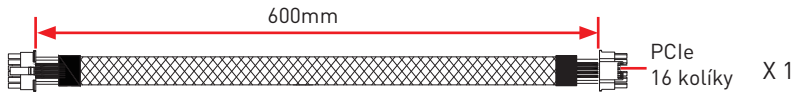
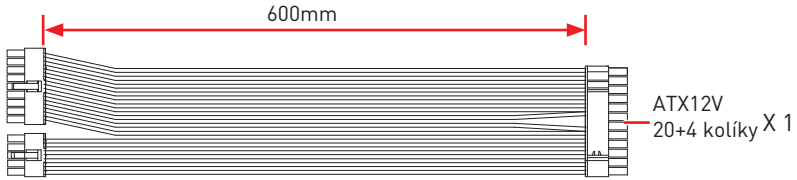

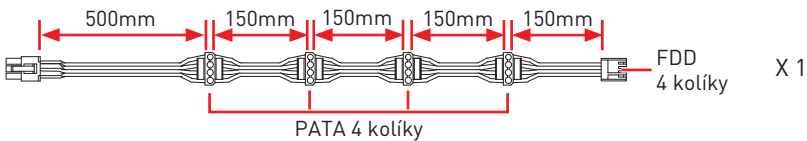
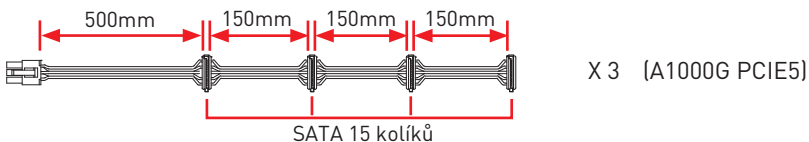
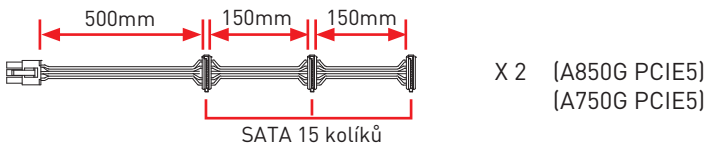
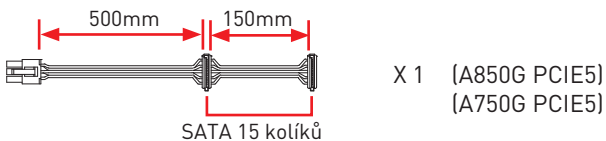
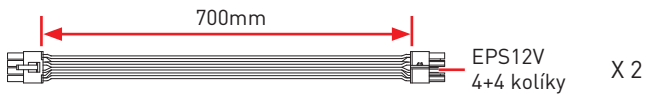

Instalace 16 kolíkového kabelu PCIe



POZOR

Před použitím kabel zcela zasuňte.

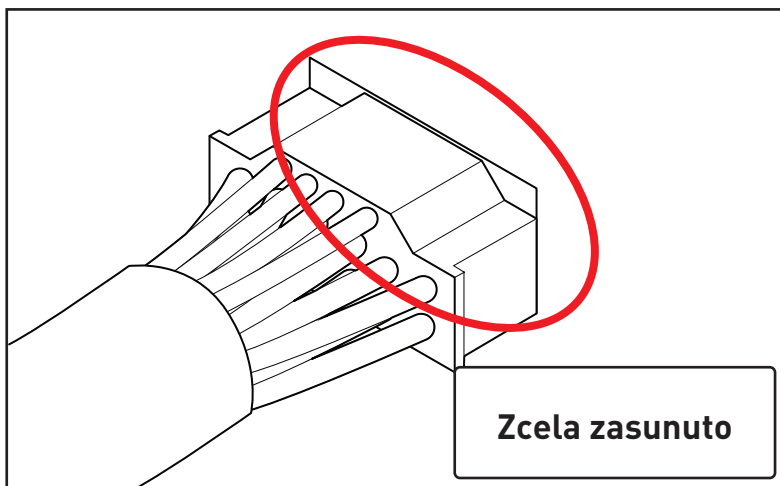
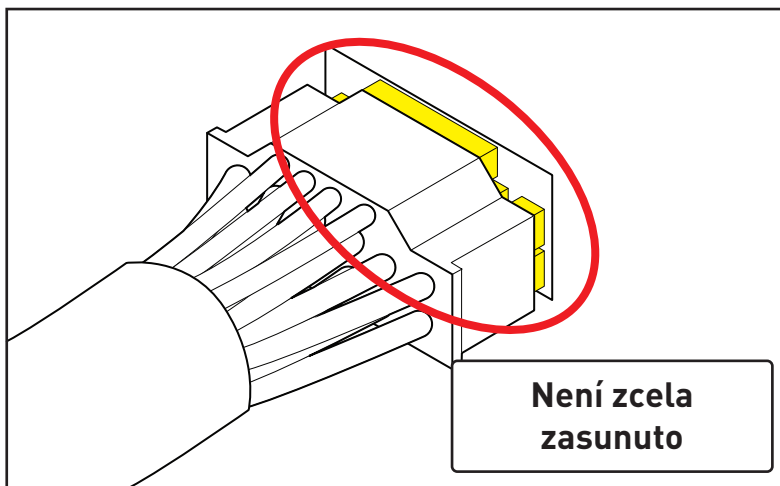

Tlačítko Zero Fan

Stisknutím tlačítka nulového ventilátoru zapnete nebo vypnete **režim ventilátoru s nulovými otáčkami**.

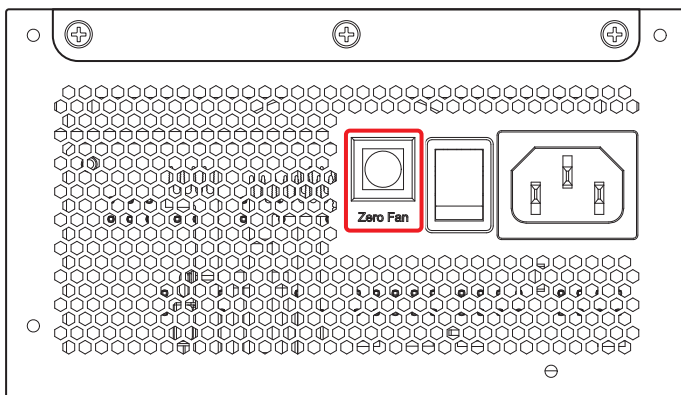

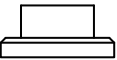
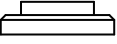
Tlačítko Zero Fan	Režim ventilátoru s nulovými otáčkami	Popis
 Nestisknuto	ZAP. (Výchozí)	Ventilátor PSU se zastaví, když zatížení systému klesne pod určenou úroveň.
 Stisknuto	VYP.	Ventilátor PSU běží neustále.

Důležité

Ve výchozím nastavení je aktivní režim ventilátoru s nulovými otáčkami; stisknutím tlačítka jej deaktivujete.

Obsah

Technické údaje.....	2
Rozmery	3
Počet napájacích konektorov	4
Odpojiteľné konektory	5
Možnosti pripojenia a dĺžky káblov	6
Inštalácia kábla PCIe so 16 kolíkmi	8
Tlačidlo Zero Fan.....	9

Technické údaje

1000 W					
Napätie	+5V	+3,3V	+12V	-12V	+5Vsb
Max. záťaž	22,0 A	22,0 A	83,5 A	0,3 A	3,0 A
Min. záťaž	0,0 A	0,0 A	0,0 A	0,0 A	0,0 A
Kombinovaný výkon (+5 V a +3,3 V)	120 W		1000 W	3,6 W	15,0 W
Celkový výkon	1000 W				
Regulácia	± 5%	± 5%	± 5%	± 5%	± 5%
Zvlnenie a šum	30 mVš-š	30 mVš-š	50 mVš-š	40 mVš-š	40 mVš-š

850 W					
Napätie	+5V	+3,3V	+12V	-12V	+5Vsb
Max. záťaž	22,0 A	22,0 A	70,8 A	0,3 A	3,0 A
Min. záťaž	0,0 A	0,0 A	0,0 A	0,0 A	0,0 A
Kombinovaný výkon (+5 V a +3,3 V)	120 W		850 W	3,6 W	15,0 W
Celkový výkon	850 W				
Regulácia	± 5%	± 5%	± 5%	± 5%	± 5%
Zvlnenie a šum	30 mVš-š	30 mVš-š	50 mVš-š	40 mVš-š	40 mVš-š

750 W					
Napätie	+5V	+3,3V	+12V	-12V	+5Vsb
Max. záťaž	22,0 A	22,0 A	62,5 A	0,3 A	3,0 A
Min. záťaž	0,0 A	0,0 A	0,0 A	0,0 A	0,0 A
Kombinovaný výkon (+5 V a +3,3 V)	120 W		750 W	3,6 W	15,0 W
Celkový výkon	750 W				
Regulácia	± 5%	± 5%	± 5%	± 5%	± 5%
Zvlnenie a šum	30 mVš-š	30 mVš-š	50 mVš-š	40 mVš-š	40 mVš-š

Rozměry

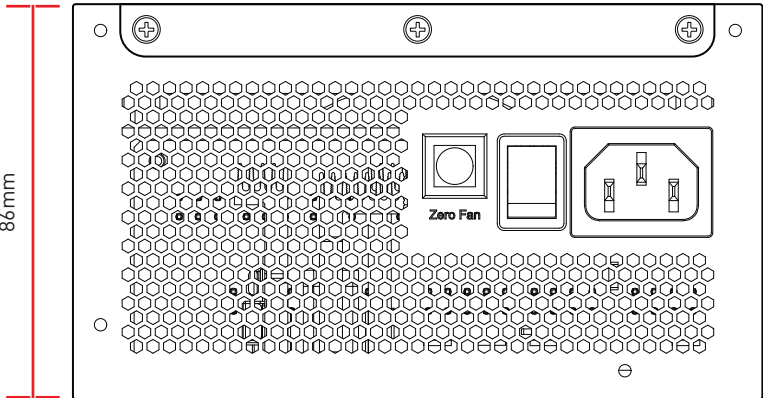
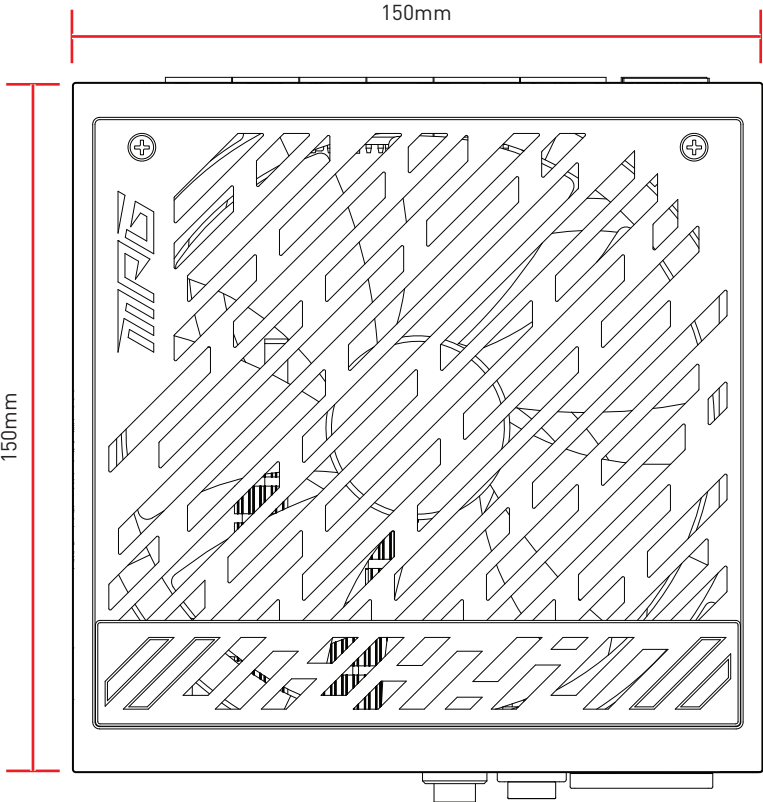

Počet napájacích konektorov

Napájacie konektory	A1000G PCIE5	A850G PCIE5	A750G PCIE5
ATX12V (základná doska) 20+4 kolíkov	1	1	1
PCIe 16 kolíkov	1	1	1
EPS12V (CPU) 4+4 kolíkov	2	2	2
PCIe (VGA) 6+2 kolíkov	6	6	6
SATA 15 kolíkov	12	8	8
Periférne zariadenia (PATA) 4 kolíky	4	4	4
FDD 4 kolíky	1	1	1

Odpojitelné konektory

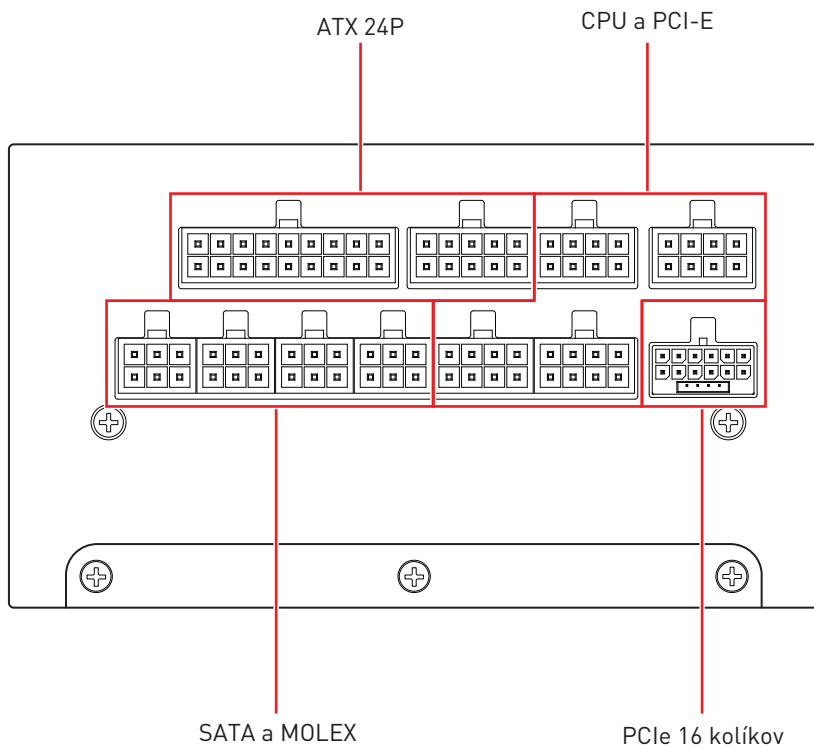

Možnosti pripojenia a dĺžky káblov

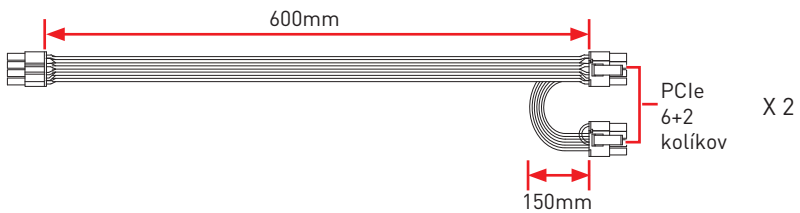
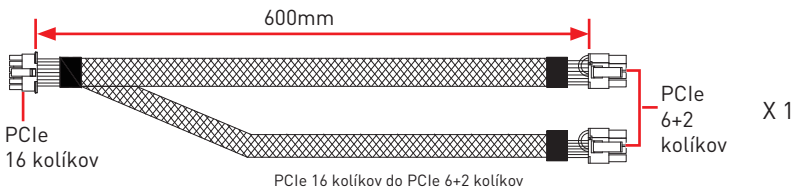
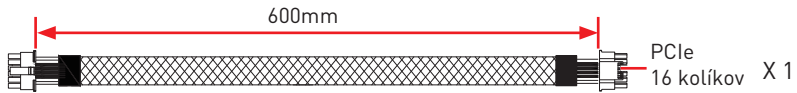
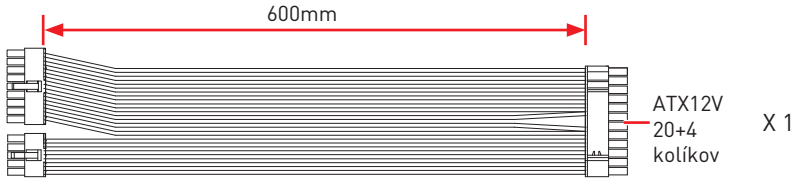

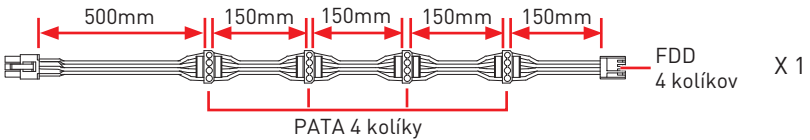
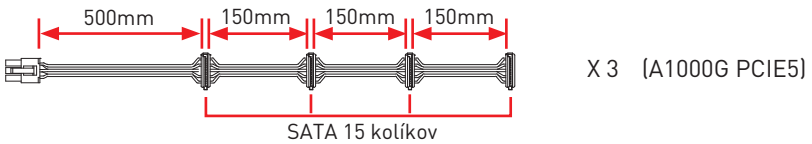
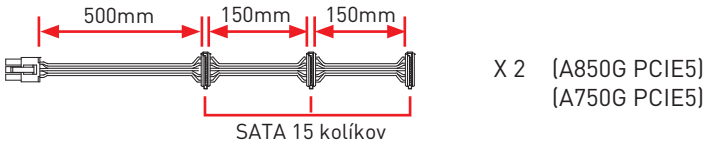
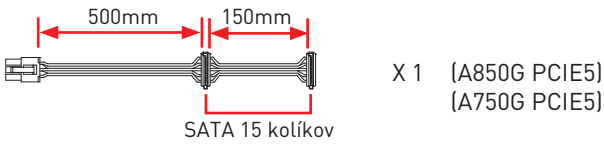

Inštalácia kábla PCIe so 16 kolíkmi

 **UPOZORNENIE**

Pred použitím úplne pripojte kábel.

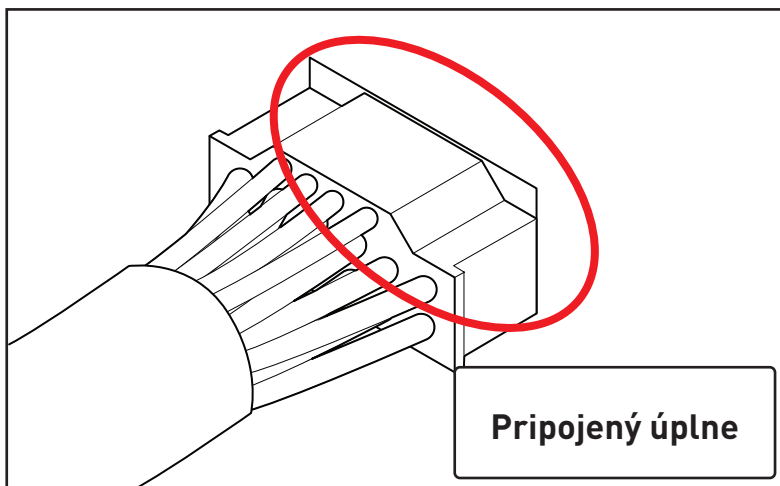
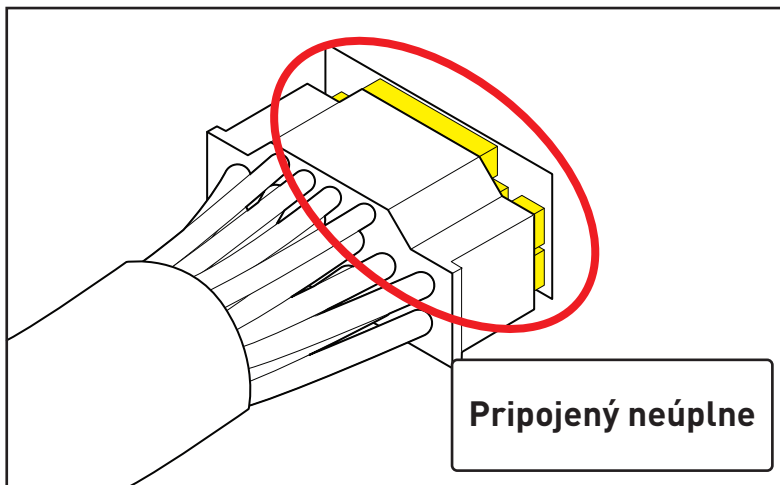

Tlačidlo Zero Fan

Stlačením tlačidla Zero Fan zapnete alebo vypnete **režim nulových otáčok ventilátora**.

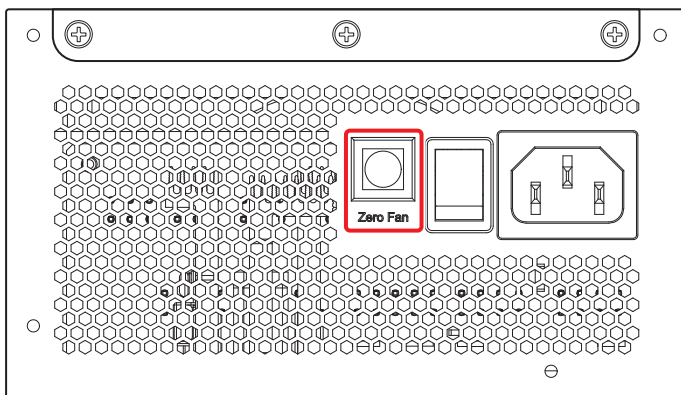

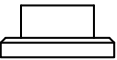
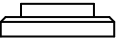
Tlačidlo Zero Fan	Režim nulových otáčok ventilátora	Popis
 Nestlačené	Zapnutie (Predvolené nastavenie)	Keď zaťaženie systému klesne pod určenú úroveň, ventilátor PSU sa zastaví.
 Stlačené	Vypnutie	Ventilátor PSU bude bežať nepretržite.

Dôležité

Režim nulových otáčok ventilátora je aktívny pri predvolenom nastavení; stlačením príslušného tlačidla ho deaktivujete.

Regulatory Notices

KC인증서

MPG A1000G PCIE5



XU100111-22090B
R-R-MSI-MPGA1000G

제품명: 컴퓨터용 전원공급장치
모델: MPG A1000G PCIE5
A/S TEL: 1644-4038
제조사: Channel Well Technology (Guangzhou) Co., Ltd.
제조국가: 중국

MPG A850G PCIE5



XU100111-22089B
R-R-MSI-MPGA1000G

제품명: 컴퓨터용 전원공급장치
모델: MPG A850G PCIE5
A/S TEL: 1644-4038
제조사: Channel Well Technology (Guangzhou) Co., Ltd.
제조국가: 중국

MPG A750G PCIE5



XU100111-22088B
R-R-MSI-MPGA750G

제품명: 컴퓨터용 전원공급장치
모델: MPG A750G PCIE5
A/S TEL: 1644-4038
제조사: Channel Well Technology (Guangzhou) Co., Ltd.
제조국가: 중국

Model Number

Model No.: 7ZP7C, 7ZP7B, 7ZP7A



Приложение к руководству пользователя

1. Оборудование

- блок питания

2. Модель

- MPG A1000G PCIE5
- MPG A850G PCIE5
- MPG A750G PCIE5

3. Торговая марка

msi

4. Назначение

- Источник питания преобразует переменный ток в постоянный, и стабильный источник питания обеспечивает бесперебойную работу всей системы

5. Технические характеристики

- Приведены в Руководстве Пользователя (раздел «Технические характеристики»)

6. Изготовитель, Адрес изготовителя

- MICRO-STAR INTERNATIONAL CO., LTD.
- 235, Тайвань, г. Нью-Тайбэй, район Чжунхэ, ул. Лиде, д. 69

7. Страна производства

- Китай

8. Юридическое лицо, осуществляющее действия от имени Изготовителя при оценке соответствия и выпуске в обращение продукции на территории Евразийского Экономического Союза (ЕАЭС), а также ответственное за несоответствие продукции требованиям технических регламентов Таможенного союза, технических регламентов ЕАЭС.

“Универсальная сертификационная компания”.

117630, город Москва, Внутригородская территория города Муниципальный округ Обручевский, Старокалужское шоссе, дом 65, этаж 7, помещение I, комната 24, Российская Федерация.

Телефон: +74956262824

адрес электронной почты: info@unicertcom.ru.

9. Соответствует

- ТР ТС 004/2011 «О безопасности низковольтного оборудования»
- ТР ТС 020/2011 «Электромагнитная совместимость технических средств»
- ТР ЕАЭС 037/2016 «Об ограничении применения опасных веществ в изделиях электротехники и радиоэлектроники»

10. Знак обращения на рынке



11. Правила и условия безопасной эксплуатации (использования)

- Предоставлено в буклете «важная информация»

12. Правила и условия монтажа

- Предоставлено в Руководстве пользователя

13. Правила и условия хранения

- Предоставлено в буклете «важная информация»

14. Правила и условия транспортировки

- Предоставлено в буклете «важная информация»

15. Правила и условия реализации

- Без ограничений

16. Правила и условия утилизации

- По окончании срока службы оборудования, пожалуйста, свяжитесь с авторизованным сервисным центром MSI, чтобы получить информацию о его утилизации.

17. Действия в случае обнаружения неисправности оборудования

- В случае обнаружения неисправности:
 1. Выключите блок питания
 2. Отсоедините вилку кабеля питания от электрической сети.
 3. Подключите вилку кабеля питания к электрической сети.
 4. Включите устройство.
 5. Если действия, описанные в п. 1.-4. , не привели к желаемому результату, обратитесь, пожалуйста, в техническую поддержку MSI или в авторизованный сервисный центр MSI.

Техническая поддержка MSI

Горячая линия: 8 800 700 77 08

Для Москвы: +7 (495) 981 45 09

E-mail: RUSupport@msi.com

Список авторизованных сервисных центров MSI представлен на сайте

<https://ru.msi.com>

18. Месяц и год изготовления оборудования

- Дата изготовления (год. месяц) можно отслеживать с помощью номера SN, напечатанного на наклейке со штрих-кодом

